

VESDA-E VEP-A10-P

Product Guide

VEP-A10-P (4 Pipes)

April 2016

Document: 22071_11

Part Number: 30311

Intellectual Property and Copyright

This document includes registered and unregistered trademarks. All trademarks displayed are the trademarks of their respective owners. Your use of this document does not constitute or create a licence or any other right to use the name and/or trademark and/or label.

This document is subject to copyright owned by . You agree not to copy, communicate to the public, adapt, distribute, transfer, sell, modify or publish any contents of this document without the express prior written consent of Xtralis.

Disclaimer

The contents of this document is provided on an “as is” basis. No representation or warranty (either express or implied) is made as to the completeness, accuracy or reliability of the contents of this document. The manufacturer reserves the right to change designs or specifications without obligation and without further notice. Except as otherwise provided, all warranties, express or implied, including without limitation any implied warranties of merchantability and fitness for a particular purpose are expressly excluded.

General Warning

This product must only be installed, configured and used strictly in accordance with the General Terms and Conditions, User Manual and product documents available from Xtralis. All proper health and safety precautions must be taken during the installation, commissioning and maintenance of the product. The system should not be connected to a power source until all the components have been installed. Proper safety precautions must be taken during tests and maintenance of the products when these are still connected to the power source. Failure to do so or tampering with the electronics inside the products can result in an electric shock causing injury or death and may cause equipment damage. Xtralis is not responsible and cannot be held accountable for any liability that may arise due to improper use of the equipment and/or failure to take proper precautions. Only persons trained through an Xtralis accredited training course can install, test and maintain the system.

Liability

You agree to install, configure and use the products strictly in accordance with the User Manual and product documents available from Xtralis.

Xtralis is not liable to you or any other person for incidental, indirect, or consequential loss, expense or damages of any kind including without limitation, loss of business, loss of profits or loss of data arising out of your use of the products. Without limiting this general disclaimer the following specific warnings and disclaimers also apply:

Fitness for Purpose

You agree that you have been provided with a reasonable opportunity to appraise the products and have made your own independent assessment of the fitness or suitability of the products for your purpose. You acknowledge that you have not relied on any oral or written information, representation or advice given by or on behalf of Xtralis or its representatives.

Total Liability

To the fullest extent permitted by law that any limitation or exclusion cannot apply, the total liability of Xtralis in relation to the products is limited to:

- i. in the case of services, the cost of having the services supplied again; or
- ii. in the case of goods, the lowest cost of replacing the goods, acquiring equivalent goods or having the goods repaired.

Indemnification

You agree to fully indemnify and hold Xtralis harmless for any claim, cost, demand or damage (including legal costs on a full indemnity basis) incurred or which may be incurred arising from your use of the products.

Miscellaneous

If any provision outlined above is found to be invalid or unenforceable by a court of law, such invalidity or unenforceability will not affect the remainder which will continue in full force and effect. All rights not expressly granted are reserved.

Scope

The VESDA-E VEP-A10-P Product Guide provides a comprehensive description of the VESDA-E VEP-A10-P detector and its accessories.

This guide introduces the VEP-A10-P features, technical specifications and gives an understanding of its components and their function. You will also find instructions on installing, cabling and powering up the detector.



This guide is for anyone involved with the design, maintenance and purchasing of a VESDA-E system. It is assumed that anyone using this product has the knowledge and appropriate certification from local fire and electrical authorities.

Document Conventions

The following typographic conventions are used in this document:

Convention	Description
Bold	Used to denote: emphasis. Used for names of menus, menu options, toolbar buttons
<i>Italics</i>	Used to denote: references to other parts of this document or other documents. Used for the result of an action.

The following icons are used in this document:

Convention	Description
	Caution: This icon is used to indicate that there is a danger to equipment. The danger could be loss of data, physical damage, or permanent corruption of configuration details.
	Warning: This icon is used to indicate that there is a danger of electric shock. This may lead to death or permanent injury.
	Warning: This icon is used to indicate that there is a danger of inhaling dangerous substances. This may lead to death or permanent injury.

Contact Us

UK and Europe	+44 1442 242 330
D-A-CH	+49 431 23284 1
The Americas	+1 781 740 2223
Middle East	+962 6 588 5622
Asia	+86 21 5240 0077
Australia and New Zealand	+61 3 9936 7000
www.xtralis.com	

Codes and Standards Information for Air Sampling Smoke Detection

We strongly recommend that this document is read in conjunction with the appropriate local codes and standards for smoke detection and electrical connections. This document contains generic product information and some sections may not comply with all local codes and standards. In these cases, the local codes and standards must take precedence. The information below was correct at time of printing but may now be out of date, check with your local codes, standards and listings for the current restrictions.

FCC Compliance Statement

This equipment has been tested and found to comply with the limits for a Class B digital device, pursuant to part 15 of the FCC Rules. These limits are designed to provide reasonable protection against harmful interference in a residential installation. This equipment generates, uses and can radiate radio frequency energy and, if not installed and used in accordance with the instruction, may cause harmful interference to radio communications. However, there is no guarantee that interference will not occur in a particular installation. If this equipment does cause harmful interference to radio or television reception, the user is encouraged to try to correct the interference by one or more of the following measures; re-orientate or relocate the receiving antenna, increase the separation between the equipment and receiver, connect the equipment to a power outlet which is on a different power circuit to the receiver or consult the dealer or an experienced radio/television technician for help.

FDA

This Xtralis product incorporates a laser device and is classified as a Class 1 laser product that complies with FDA regulations 21 CFR 1040.10. The laser is housed in a sealed detector chamber and contains no serviceable parts. The laser emits light which can be hazardous to the eye. Under no circumstances should the detector chamber be opened.

The laser chamber is identified by the labels shown below:



AS1603.8

The performance of this product is dependent upon the configuration of the pipe network. Any extensions or modifications to the pipe network may cause the product to stop working correctly. All pipe network designs must be validated using ASPIRE. ASPIRE is available from your authorized representative.

The product is not intended to be mounted in hostile environments but is able to sample from hostile environments.

AS1851.1 2005

Maintenance Standards. Wherever this document and the AS1851.1 differ, AS1851.1 should be followed in preference to this document.

Regional Regulatory Requirements and Notices

UL and ULC

For open area, open area high velocity and duct protection the fire alarm threshold (setting) that initiates an evacuation signal must be set such that the sensitivity of each sampling hole is more sensitive than 10%/m (3.2 %/ft) as determined by the ASPIRE software.

European Installations

The product must use a power supply conforming to EN54: Part 4.

EN 54-20

The product must use a power supply conforming to EN 54-4.

The product is compliant with EN 54-20 sensitivity requirements provided the following conditions are met:

- For a Class A detector, hole sensitivity must be better than 1.5% obscuration/m and transport time less than 60 seconds
- For a Class B detector, hole sensitivity must be better than 3% obscuration/m and transport time less than 90 seconds
- For a Class C detector, hole sensitivity must be better than 8% obscuration/m and transport time less than 110 seconds

These limits should be verified using ASPIRE during the design of the sampling pipe network.

The product is compliant with EN 54-20 flow monitoring requirements provided the following conditions are met:

- The minor low and minor high flow thresholds should be set at 85% and 115% respectively
- The flow through the detector predicted by ASPIRE must be greater than 20 L/m.

Product Listings

Regional approvals listings and regulatory compliance vary between product models. Refer to www.xtralis.com for the latest product approvals matrix.

Document: 22071_11

Part Number: 30311

Table of Contents

1	Introduction	3
1.1	Features	3
2	Product Information	5
2.1	Detector Components	5
2.2	How the VEP-A10-P works	5
2.3	Front Panel	6
2.4	Internal Buttons	8
2.5	Communication Ports	9
2.6	VESDAnet	9
2.7	Specifications	11
2.8	Dimensions	13
3	Pipe Network Design and Installation	17
3.1	Design Considerations	17
3.2	Installation Considerations	17
3.3	Pipe Inlets	17
3.4	Managing the Exhaust Air	18
4	Installation	19
4.1	Prepare the Detector	19
4.2	Mounting	20
4.3	Wiring	35
4.4	Powering Up	45
4.5	Installation Checklist	46
4.6	Preliminary System Check	47
5	Configuration	49
5.1	Communication between Xtralis VSC and the detector	49
5.2	Connecting to the Detector	53
5.3	Security	56
5.4	Commands	57
5.5	Configuration Options	60
5.6	Factory Default Settings	73
6	Commissioning	77
6.1	AutoLearn Smoke	77
6.2	AutoLearn Flow	78
6.3	Commissioning Smoke Test	78
7	Maintenance	79
7.1	Standby	79
7.2	Open the Door	80
7.3	Replacing the Filter	81
7.4	Remove the Fascia	84
7.5	Replacing the Aspirator	86
7.6	Replacing the Smoke Detection Chamber	88
7.7	Replacing the Sampling Module	92
7.8	Spare Parts	96
8	Troubleshooting	97
8.1	Fault Reporting through Relays	97
8.2	Troubleshooting with the Front Panel Display	97
8.3	Troubleshooting with Xtralis VSC	98
A	Commissioning Forms	99
A.1	VEP-A10-P Detector Commissioning Configuration	101
A.2	ASPIRE Data	101

A.3 Smoke Test 101

A.4 Air Sampling Test Results 101

B Glossary 103

Index 105

1 Introduction

The VESDA-E VEP-A10-P is an aspirating smoke detector (ASD) that provides very early warning of fire conditions by drawing air samples through an air sampling pipe network.



Figure 1-1: VESDA-E VEP-A10-P Aspirating Smoke Detector

The detector easily interfaces with fire warning and fire suppression release systems, and can be integrated into a building management system (BMS).

1.1 Features

The VEP-A10-P detector contains the following features:

- Short wavelength laser-based detection
- Inherent absolute calibration
- Clean air barrier for optics protection
- More robust contamination resistance
- Wide sensitivity range
- Flow fault thresholds configurable per port
- Long-life, easy-to-replace air sample filter
- 3.5" colour touch screen for status review
- Quiet operation
- Advanced remote diagnostics
- Area coverage:
 - up to 2,000 m² (21,520 ft²) (VEP-A10-P)
- Up to four inlet pipes
- Total maximum pipe length:
 - Four pipe VEP-A10-P: 560 m (1,837 ft)
- Referencing
- AutoLearn™ Smoke and Flow
- Seven programmable relays
- Two General Purpose Inputs (GPIs), one monitored and one unmonitored
- Ultrasonic flow sensing
- Xtralis VSC, Xtralis VSM4 and ASPIRE PC software support
- IP 40 enclosure (not UL tested)
- Easy mounting with steel support bracket
- Field replaceable aspirator, sampling module, filter and detection chamber
- VESDAnet networking
- Ethernet 100 base T
- WiFi, 802.11 b/g/n
- Local host mode USB port
- Easy cable termination access
- Event Log (20,000 events)

This page is intentionally left blank.

2 Product Information

2.1 Detector Components

The VEP-A10-P detector contains field-replaceable Filter, Aspirator and Chamber Assembly components. These are shown below in Figure 2-1.

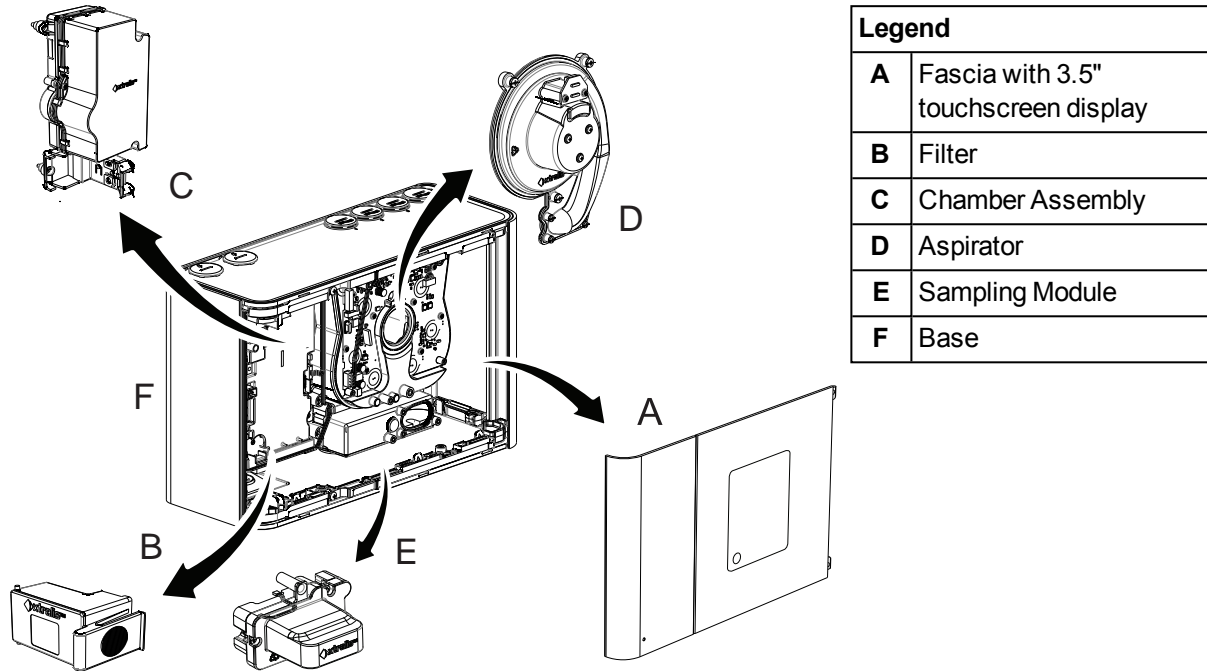

Figure 2-1: Detector components

Refer to Chapter 7 for further information regarding maintenance scheduling and availability of spare parts.

2.2 How the VEP-A10-P works

An air sampling pipe network collects samples from the protected area. The integrated aspirator draws air into the sampling pipe(s).

The air from each sampling pipe passes through an air flow sensor and then a sample of the air is drawn into the smoke detection chamber via the sampling module, after first passing through the replaceable filter.

A further filter provides filtered clean air to protect the optical surfaces inside the detection chamber from contamination.

The detection chamber uses a short wavelength laser light source in conjunction with photodiodes and advanced imaging technology to achieve optimum response to a wide range of smoke types.

If the detected smoke is higher than the set alarm thresholds it is reported as an Alert, Action, Fire 1 or Fire 2 alarm condition.

Air is exhausted from the VEP-A10-P and may be vented back into the protected zone.

Alarms can be signalled via Relays and VESDAnet. Ethernet and WiFi can be used for configuration and secondary monitoring, and a USB interface is provided for initial setup.

The detector has a LED plus LCD user interface. A series of LEDs display Alarm, Fault, Disable and detector power on status. A button allows the user to Reset or Disable the detector. In addition an LCD displays detector status including smoke level and a smoke level bar graph, alarm thresholds, trouble status, % airflow level, normalization status and filter life used.

2.3 Front Panel







The VEP-A10-P detector provides the following information and control capability:

- **Status LEDs:** Alert, Action, Fire 1, Fire 2, Disabled, Fault and Power.
- **Controls:** Reset and Disable button. Touch-screen featuring a limited set of additional controls and lookup tools.

2.3.1 Status LEDs

The VESDA-E VEP-A10-P detector features a range of LED Indicators which illuminate when their respective activation conditions are met.

Table 2-1: LED Indicators

LED	Symbol	Description
Fire 2		The Fire 2 LED is lit when the Fire 2 Alarm threshold is reached.
Fire 1		The Fire 1 LED is lit when the Fire 1 Alarm threshold is reached.
Action		The Action LED is lit when the Action threshold is reached.
Alert		The Alert LED is lit when the Alert threshold is reached.
Disabled		The DISABLED LED is lit continuously when the detector is disabled and flashes once every two seconds when the detector is in Standby mode.
Fault		The FAULT LED is lit when a fault condition is detected. Refer to Chapter 8 for information on troubleshooting.
Power		The POWER LED illuminates when the detector is powered up.

Notes:

- The LEDs are tested during the power up cycle. To manually test the LEDs, run the Lamp Test using Xtralis VSC.

2.3.2 RESET / DISABLE Button



Figure 2-2: Reset / Disable Button

Resetting the detector unlatches all latched alarms and faults, returns relays to their normal state and clears the active event list in Xtralis VSC.

- To reset the detector, press this button once.

Disabling the detector disables signaling of alarms and faults via the relays. The aspirator remains active.

Disabled mode is signaled on relay #1 by default. Other relays may also be configured to signal disabled mode. Refer to sections 4.3.6 and 5.5.10 for further information. For example, disabled mode may be also signaled as an additional condition on the Fault Relay (Relay #3).

- To disable the detector, press and hold the button for approximately 4 seconds, until the DISABLED LED illuminates continuously.
- To re-enable the unit, press and hold the button for approximately 4 seconds, until the DISABLED

LED deactivates continuously.

- While the detector is disabled, any faults may be cleared by pressing this button once.

The button will not operate if:

- the detector is disabled through the GPI function; or
- the RESET / DISABLE button has been configured as "locked out". Refer to section 5.5.11 for further information.

2.3.3 Touch Screen

The built in 3.5" touch screen provides a range of status information, accessible via a series of screens.

Main Screen

The Main Screen displays a set of important information concerning the detector and its overall status. Information and indicators include:

- Model number
- Location
- Current smoke level
- Current overall fault state
- Individual faults

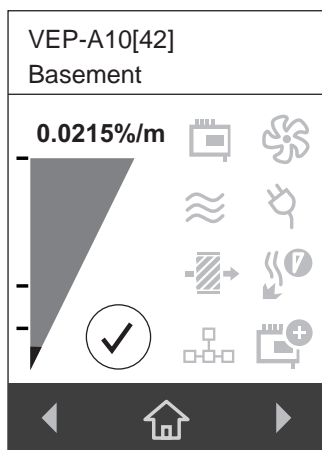

Figure 2-3: Main Screen - Normal System

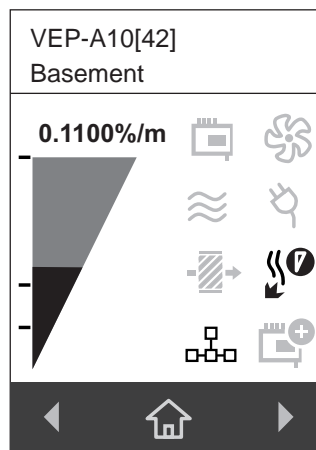

Figure 2-4: Main Screen - System with Faults

Note: Refer to Section 8.2 on page 97 for further information on troubleshooting using the fault display information on the main screen.

Airflow Screen

The Airflow screen displays the flow level for each of the sampling pipes that are in use. Sampling pipes that have been deactivated are identified with a cross.

Note: Refer to Section 3.3 on page 17 for further information on Sampling Pipe configuration.

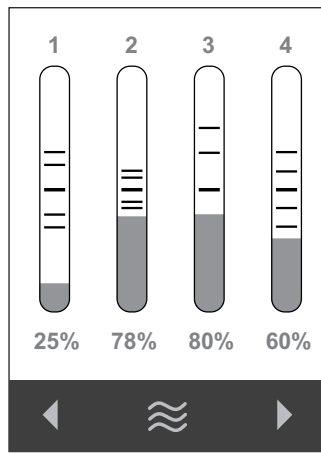

Figure 2-5: Airflow Screen

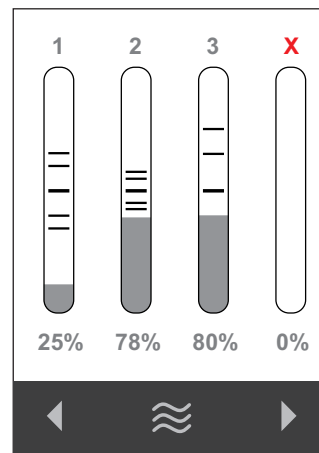

Figure 2-6: Airflow Screen with a disabled Sampling Pipe

Note: VEP-A10-2P detectors show only two pipes.

Status Screen

The Status screen displays a usage indicator for the filter and status information for the Normalization, AutoLearn Smoke and AutoLearn Flow functions.

Note: Refer to Chapter 6 for further information on the Normalization, AutoLearn Smoke and AutoLearn Flow functions.



Figure 2-7: Status Screen

Navigation

Press Left or Right arrows at the bottom of the screen to cycle through the available screens.

2.4 Internal Buttons

AutoConfig

- To normalize the detector, press and hold the button until the AutoConfig LED illuminates continuously (approximately 2 seconds), then release the button.
- To initiate AutoLearn Smoke and Flow, press and hold the AutoConfig button until the AutoConfig LED starts flashing (approximately 15 seconds), then release the button.
- Cancel the AutoLearn or Normalization functions by pressing and holding the AutoConfig button for 5 seconds. The LED will turn off. If AutoLearn is halted, the flow and smoke thresholds will be left at the previous settings.

2.5 Communication Ports

The majority of user operations are performed using software installed on a computer connected to the detector via one of the physical communication ports or WiFi. The correct connection method to use depends on the purpose for connecting to the detector (Figure 2-8).

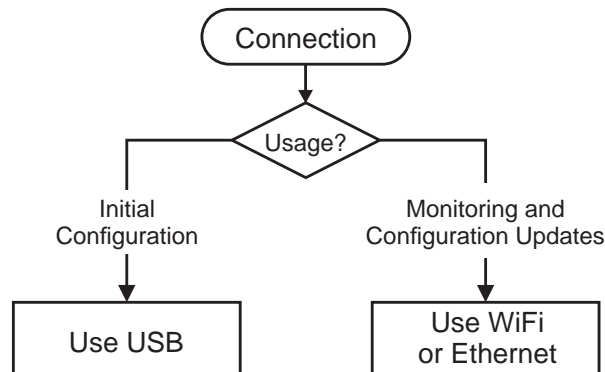

Figure 2-8: Connection Method

The physical communication ports are located on the main board inside the detector. It is necessary to open the front door in order access these ports. Refer to Section 7.2 for information on opening the front door.

USB

The USB port is used for configuration purposes ONLY. It allows direct connection between the VEP-A10-P detector and a PC or laptop running the Xtralis VSC software.

Refer to Section 4.3.4 for information on connecting the USB lead, and Section 5.1.2 for information on creating connection profiles in Xtralis VSC.

Note: The USB port must not be used for permanent field connection. For example, do not use a USB to Ethernet or USB to Wifi adaptor to connect the detector to a LAN using USB.

Ethernet

The Ethernet port is used for configuration and/or monitoring purposes. It enables direct or routed network connection between the detector and a PC or laptop installed with Xtralis VSC.

Refer to Section 4.3.4 for information on connecting the Ethernet lead, and Section 5.1.2 for information on creating connection profiles in Xtralis VSC.

A password is required to access the detector via ethernet connection. It is initially set using Xtralis VSC during configuration with the USB port, and the user is required to enter it when creating an Ethernet connection profile in Xtralis VSC. It is also necessary to enter additional PIN codes to access administrative and distributor functions. Refer to Section 5.3 on page 56 for further information.

WiFi

The WiFi module provides wireless connection of the detector to the building network for the purpose of configuration and secondary monitoring with Xtralis VSC. The VEP-A10-P is joined to a wireless network during initial configuration and remains connected while the access point is available.

Successful connection of the detector to the specified network is indicated by the WiFi LED inside the detector. The detector is then accessible using a device that is connected to the same access point that the detector is connected to, or a device that is joined to the same network as the access point that the detector is connected to.

A password is required to access the detector via WiFi connection. It is initially set using Xtralis VSC during configuration with the USB port, and the user is required to enter it when creating a WiFi connection profile in Xtralis VSC. It is also necessary to enter additional PIN codes to access administrative and distributor functions. Refer to Section 5.3 on page 56 for further information.

2.6 VESDAnet

A VESDAnet network allows:

- the VEP-A10-P detector to report alarms and faults to a Fire Panel using a remote display module, remote relay module or HLI.
- configuration and monitoring of devices from a central computer.
- connection to a reference detector.

Gateway function of the VEP-A10-P

The VEP-A10-P detector also provides a gateway to the VESDAnet for a PC running Xtralis VSC connected to the VEP-A10-P via Ethernet, USB or WiFi.

Refer to the VESDA Communications Guide for further information on VESDAnet network connectivity.

2.7 Specifications

Table 2-2: VEP-A10-P Detector Specifications

Specification	Value									
Supply Voltage	18 to 30 VDC (24 VDC Nominal)									
Power Consumption @24 VDC	<table border="1"> <thead> <tr> <th>Aspirator</th> <th>Setting 1</th> <th>Setting 5</th> </tr> </thead> <tbody> <tr> <td>Power (Quiescent)</td> <td>8.2 W</td> <td>10.0 W</td> </tr> <tr> <td>Power (in Alarm)</td> <td>10.4 W</td> <td>11.6 W</td> </tr> </tbody> </table>	Aspirator	Setting 1	Setting 5	Power (Quiescent)	8.2 W	10.0 W	Power (in Alarm)	10.4 W	11.6 W
Aspirator	Setting 1	Setting 5								
Power (Quiescent)	8.2 W	10.0 W								
Power (in Alarm)	10.4 W	11.6 W								
Dimensions (WHD)	350 mm x 225 mm x 135 mm (13.8 in x 8.9 in x 5.3 in)									
Weight	4.1 kg (9.1 lb)									
Operating Conditions Please consult your Xtralis representative for information on operation outside these parameters or where sampled air is continually above 0.05% obs/m (0.015% obs/ft) under normal operating conditions.	Temperature: <ul style="list-style-type: none"> • Ambient: 0°C to 39°C (32°F to 102°F) • Sampled Air: -20°C to 60°C (-4°F to 140°F) • Tested to: -20°C to 55°C (-4°F to 131°F)* * UL: -20°C to 50°C (-4°F to 122°F) Humidity: <ul style="list-style-type: none"> • 10-95% RH, non-condensing 									
Storage Conditions (Non-operational)	<ul style="list-style-type: none"> • Humidity: Dry (<95%) • Temperature: 0° to 85°C • Must not be exposed to sunlight or other radiation sources 									
Sampling Pipe Network	<ul style="list-style-type: none"> • Maximum length per pipe when using four straight pipes: <ul style="list-style-type: none"> • Four pipe VEP-A10-P: 70 m (230 ft) • Maximum total pipe length (with branches): <ul style="list-style-type: none"> • Four pipe VEP-A10-P: 560 m (1,837 ft) • Pipe Modeling Design Tool: ASPIRE • Minimum airflow per pipe: 15 l/m <p>Note: Standards compliance of a particular pipe network must be determined using ASPIRE.</p>									
Inlet Pipe Size	<ul style="list-style-type: none"> • External Diameter: 25 mm or 1.05 in (3/4" IPS) 									
Exhaust Pipe Size	<ul style="list-style-type: none"> • External Diameter: 25 mm or 1.05 in (3/4" IPS) via adaptor 									
Relays	<ul style="list-style-type: none"> • 7 programmable relays • Contacts rated 2A @ 30 VDC (Resistive) • Programmable to latch or not latch alarm or fault states 									
IP Rating	IP 40 (not UL tested)									
Mounting	Upright or inverted									
Cable Access	4 x 26 mm (1 in) ports									
Cable Termination	Screw terminal blocks (0.2-2.5 sq mm, 24-14 AWG)									
Interfaces	<ul style="list-style-type: none"> • USB (Type 2) • Ethernet (RJ45) • WiFi, 802.11 b/g/n 									
Dynamic Range	0.0002%/m (0.00006%/ft) to 32%/m (10%/ft)									
Sensitivity Range	0.005 to 20% obs/m (0.0016 to 6.25% obs/ft.)									

Table 2-2: VEP-A10-P Detector Specifications (continued...)

Specification	Value
Threshold Setting Range	<ul style="list-style-type: none"> • Alert: 0.005%–2.0% obs/m (0.0016% - 0.625% obs/ft) • Action: 0.005%–2.0% obs/m (0.0016% - 0.625% obs/ft) • Fire1: 0.010 %–2.0% obs/m (0.0031% - 0.625% obs/ft) • Fire2: 0.020 %–20.0% obs/m (0.0063% - 6.25% obs/ft) <p>Notes:</p> <ul style="list-style-type: none"> • UL and ULC: For open area, open area high velocity and duct protection the fire alarm threshold (setting) that initiates an evacuation signal must be set such that the sensitivity of each sampling hole is more sensitive than 10%/m (3.2 %/ft) as determined by the ASPIRE software. • Refer to Section 5.6 on page 73 for the default settings.
Referencing	Reference smoke level source.

Table 2-3: Key Software Features

Event Log	Up to 20,000 events stored on FIFO basis
AutoLearn	<ul style="list-style-type: none"> • Minimum 15 minutes • Maximum 15 days, 23 hrs, 59 minutes • Recommended 14 days <p>Thresholds are automatically changed from the previously set values to the updated values after the AutoLearn process has completed.</p>
Referencing	Adjustment for external ambient conditions
Four Alarm Levels	Alert, Action, Fire1 and Fire2
Two Fault Warning Levels	Maintenance and Major Fault
Maintenance Aids	<ul style="list-style-type: none"> • Filter and flow monitoring • Event reporting via VESDAnet and event log

Table 2-4: Ordering Information

VESDA-E VEP-A10-P Detector	VEP-A10-P (4 Pipes)
Exhaust Adaptor US	VSP-961

Note: Refer to Section Table 7-2 for the spare parts list.

2.8 Dimensions

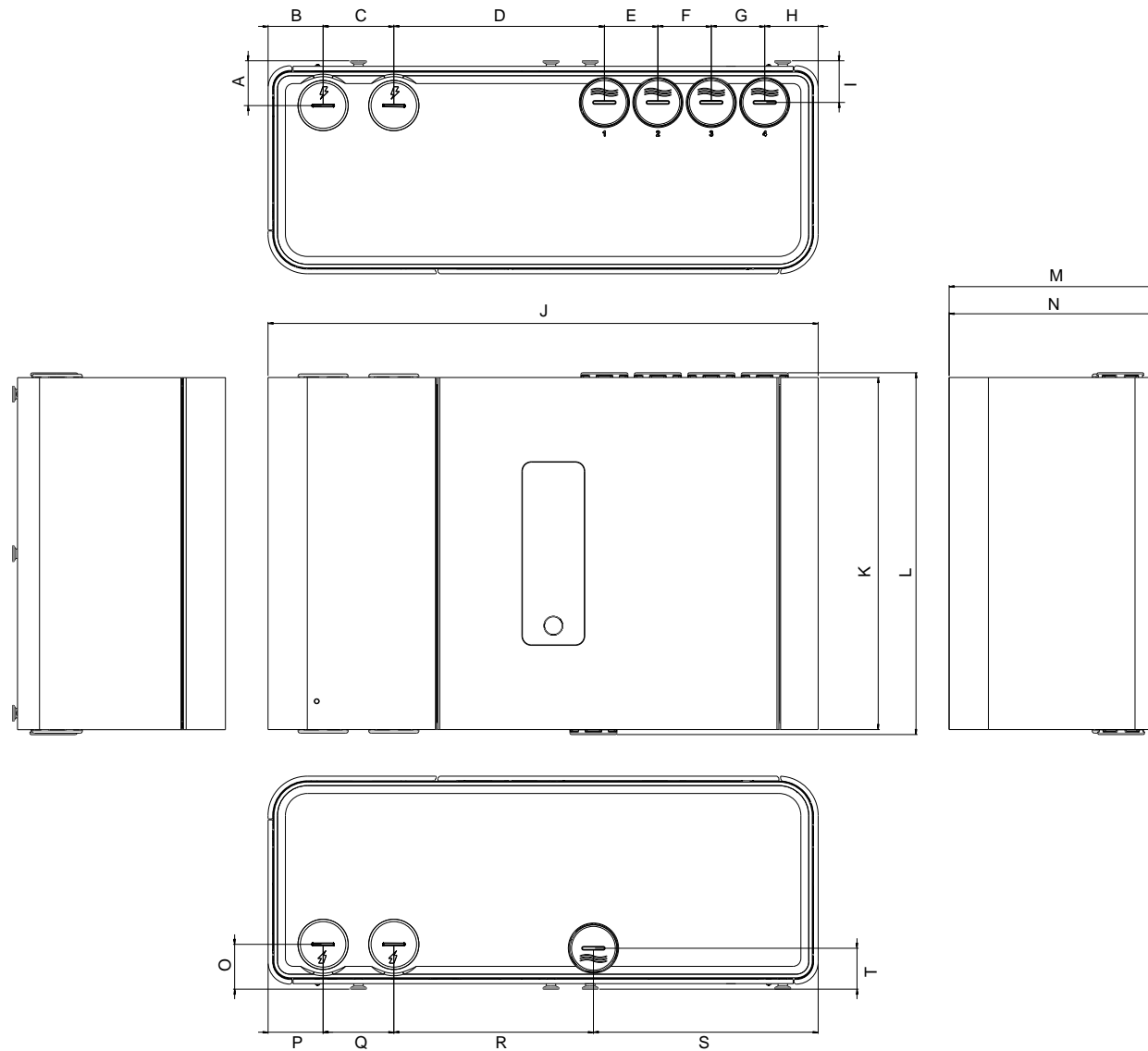

	mm	inch
A	28.5	1.12
B	35.0	1.38
C	45.0	1.77
D	134.0	5.28
E	34.0	1.34
F	34.0	1.34
G	34.0	1.34
H	34.0	1.34
I	26.5	1.04
J	350.05	13.78
K	224.0	8.82
L	230.2	9.06
M	135.48	5.3
N	132.28	5.21
O	28.5	1.12
P	35.0	1.38
Q	45.0	1.77
R	127.0	5.0
S	143.0	5.63
T	26.0	1.02

Figure 2-9: Front, top, bottom and side dimensions

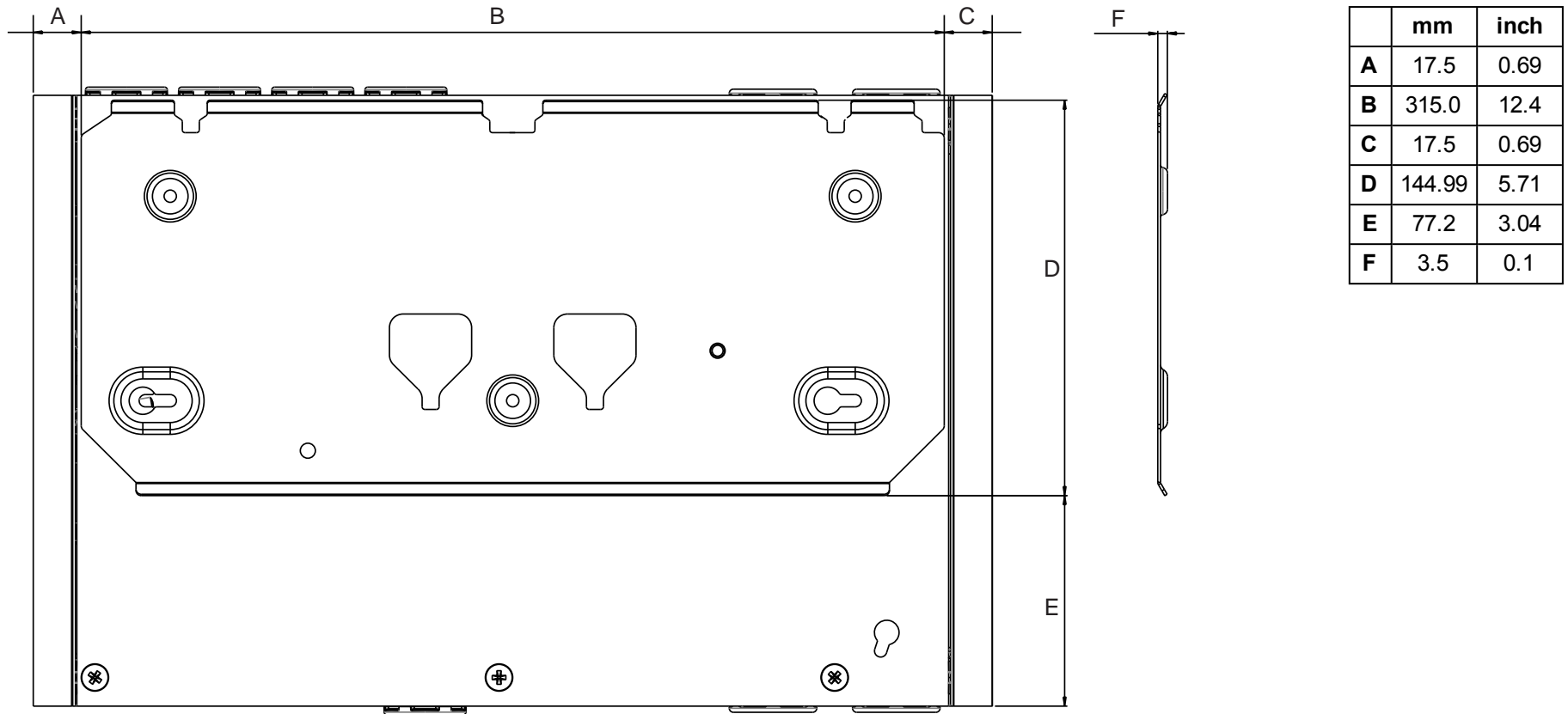
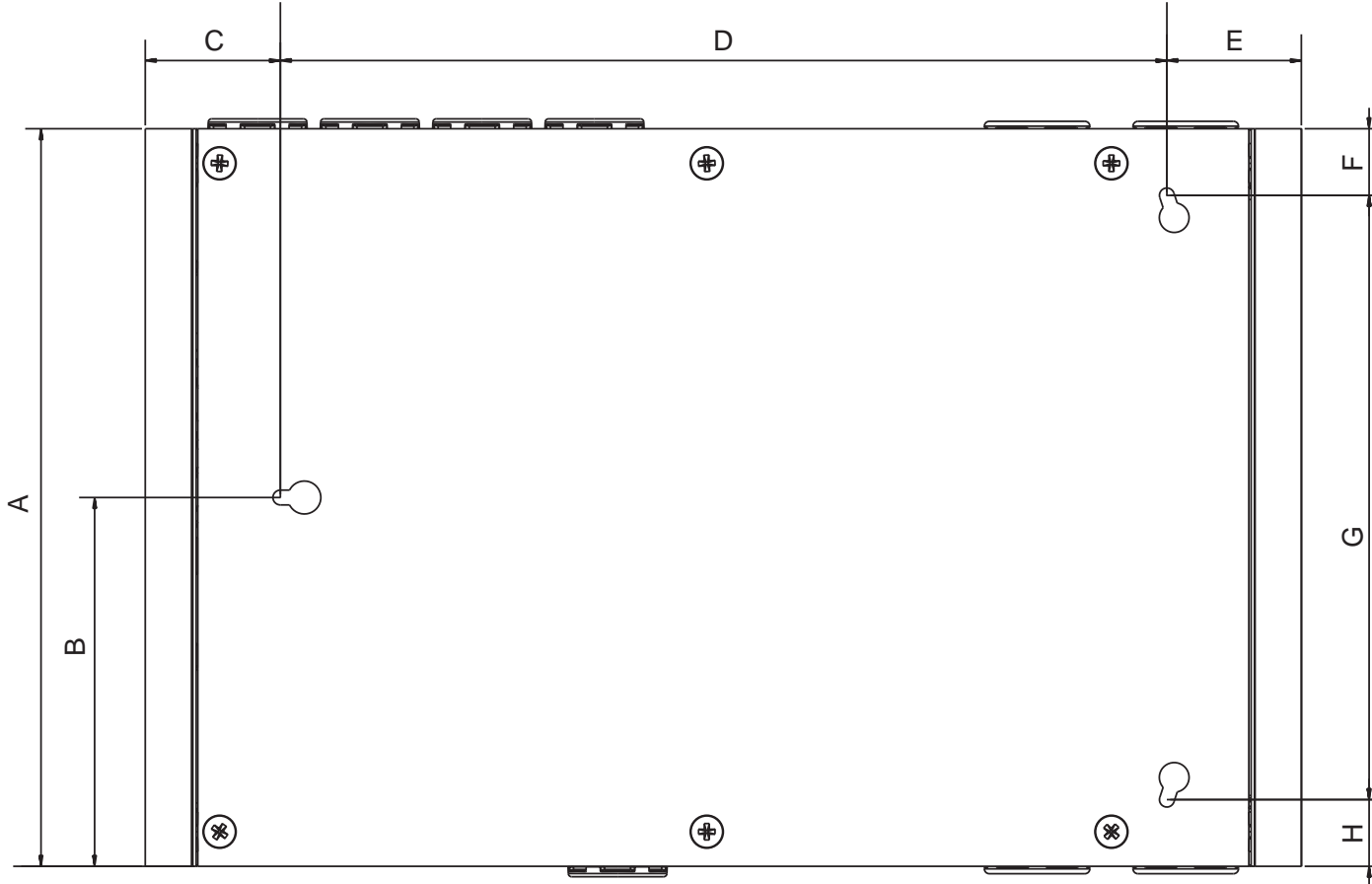

Figure 2-10: Rear dimensions with Mounting Bracket



	mm	inch
A	224.0	8.82
B	112.0	4.41
C	40.9	1.61
D	268.39	10.57
E	40.71	1.6
F	20.25	0.8
G	183.5	7.22
H	20.25	0.8

Figure 2-11: Rear Dimensions with hole locations for direct mounting

This page is intentionally left blank.

3 Pipe Network Design and Installation

The Pipe Network should be designed by trained personnel, and verified using the ASPIRE software.

3.1 Design Considerations

The following points should be considered when designing a pipe network for the VEP-A10-P detector:

- At all times the detector requires a minimum total airflow of 20 liters per minute, and 15 liters per minute per pipe for multi-pipe systems. It is highly recommended that pipe flows be set to at least 20% higher than required minimums.
- For other than single pipe installations, it is preferred to use a total detector flow rate of at least 50 l/min. Verify the design using the ASPIRE software. If required, use higher aspirator speed setting to meet this limit.
- For single pipe installations, the pipe flow rate should be at least 40 liters per minute. Verify the design using the ASPIRE software. If required, use a higher aspirator speed setting to meet this limit.
- Avoid using exhaust pipes unless there is a substantial pressure differential between the detector and the area being sampled by the pipe network. In this case the exhaust pipe needs to go back to the sampled area. Refer to Section 3.4. for further information.

Refer to the VESDA Pipe Network Design Guide for best design practices.

3.2 Installation Considerations

The following points should be considered when installing sampling pipe:

- Minimize flexing in sampling pipes by supporting the pipe every 1.5m (5ft) or less, or at a distance described in local codes and standards.
- Evenly arrange the sampling pipe network over return air grilles.
- The sampling pipe fits firmly into the tapered detector port, DO NOT glue this connection.
- Allow sufficient movement at the detector to permit pipe removal for maintenance.
- Keep the exhaust pipe as short as possible to minimize airflow resistance in the pipe.
- Pipe ends must be made smooth for bonding.
- Sampling holes must be drilled in line and perpendicular to the pipe.
- Sampling holes must be clear of rough edges and debris.
- Pipes are free of debris.
- All joints must be bonded except the end caps and pipes entering the detector.

Notes:

- Sampling holes should be angled between 30° and 45° into the direction of airflow, or point downwards in static airflow situations.
- Keep the sampling holes evenly spaced.
- For code-specific information, see Codes and Standards Information for Air Sampling Smoke Detection on page iii.

Refer to the VESDA Pipe Network Installation Guide for best installation practices.

3.3 Pipe Inlets

The air inlet ports in the pipe inlet manifold are tapered such that they accommodate both 25 mm OD pipe or IPS 3/4 inch pipe (1.05 inch OD).

Each air inlet port allows maximum insertion of the sampling pipe to a depth of 23mm for 25 mm OD pipe or 11.5mm for IPS 3/4 inch pipe (1.05 inch OD). While connecting the detector to the pipe network:

- Ensure a minimum length of 500 mm (20 in) of straight pipe before terminating the pipes at the air inlet ports of the detector.
- Square off and de-burr the end of the sampling air pipes, ensuring the pipes are free from debris.
- Determine the pipe inlet ports to be used. Refer to Table 3-1 below for details.
- Remove the plugs from only those pipe inlet ports intended for use. To remove the plug, place a large

- screwdriver in the large slot and twist, or use a small screwdriver in the side slots to lever the plug out.
- Insert the pipes into the pipe inlet(s) ensuring a firm fit.

Note: DO NOT glue the inlet pipes to the pipe inlet manifold.

When configuring the detector ensure that the correct pipes in use are selected as indicated in Table 3-1.

Table 3-1: Preferred use of pipe inlet ports

No. of Pipes		Preferred Pipe Inlet Port to use			
		Pipe 1	Pipe 2	Pipe 3	Pipe 4
VEP-A10-P	1		Inlet 2 or 3	Inlet 2 or 3	
	2		✓	✓	
	3	Inlet 1 or 4	✓	✓	Inlet 1 or 4
	4	✓	✓	✓	✓

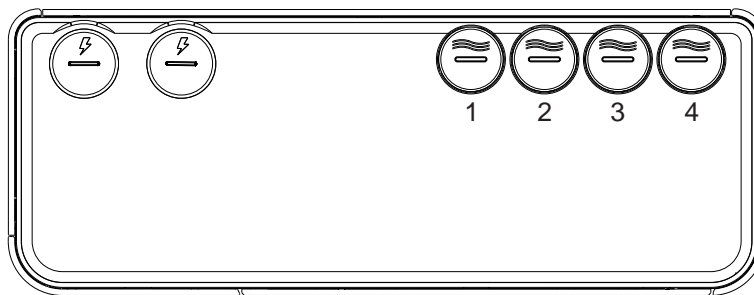

Figure 3-1: Pipe inlet port numbering

For code-specific information, refer to Codes and Standards Information for Air Sampling Smoke Detection on page iii.

3.4 Managing the Exhaust Air

Air is expelled from the detector via the exhaust port at the bottom of the unit enclosure.

The air exhaust port is tapered to accommodate standard pipes of OD 25 mm (ID 21 mm) and to provide an airtight seal. IPS 3/4 inch pipes (1.05 inch OD) require an adaptor (VSP-961) as shown in Figure 3-2. If required, connect an outlet pipe to the exhaust manifold. DO NOT glue this pipe to the exhaust manifold as this will void the warranty.

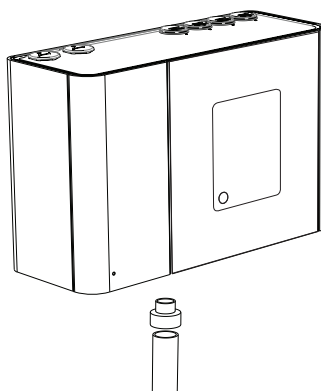

Figure 3-2: Imperial Pipe Adaptor (VSP-961)

Where the detector is located outside the protected environment, it may be necessary to return the exhaust air to the same environment. For example, where pressure differences exceed 50 Pa, or where hazardous substances are present inside the protected environment. Return air pipes need to be as short as possible to minimize the effect of airflow impedance in the return air pipe network.

4 Installation

The VEP-A10-P detector is shipped with the following components:

- 1 VESDA-E VEP-A10-P detector
- Installation Sheet
- Mounting bracket
- Mounting template for directly mounting the detector to the mounting surface
- Exhaust Adaptor (US only)
- 1 End of Line resistor for the monitored GPI

Check all components for damage and refer any concerns to your authorized representative.

Depending on the nature of the installation, it may be necessary to procure the following items:

- The latest revision of this full product guide can be downloaded from the partner extranet at www.xtralis.com.
- A 24 VDC Power Supply and backup battery, compliant with local fire protection codes and standards
- Screws and inserts for the mounting bracket that are appropriate for the installation location.
- Type A to Type B USB Interface Lead, required for initial configuration of the detector (Figure 4-1).
- Wrist strap for ESD prevention.



Figure 4-1: Type A to Type B USB Interface Lead

4.1 Prepare the Detector

- Remove tape from the exhaust port.
- Invert the fascia if required. Refer to Section 4.2.1 for further information.
- Remove cable and pipe inlet plugs as required. Place a large screwdriver in the large slot and twist (A), or use a small screwdriver in the side slots (B) to lever the plug out (Figure 4-2). Use the edge of the detector (C) for a lever point to avoid marking the case.

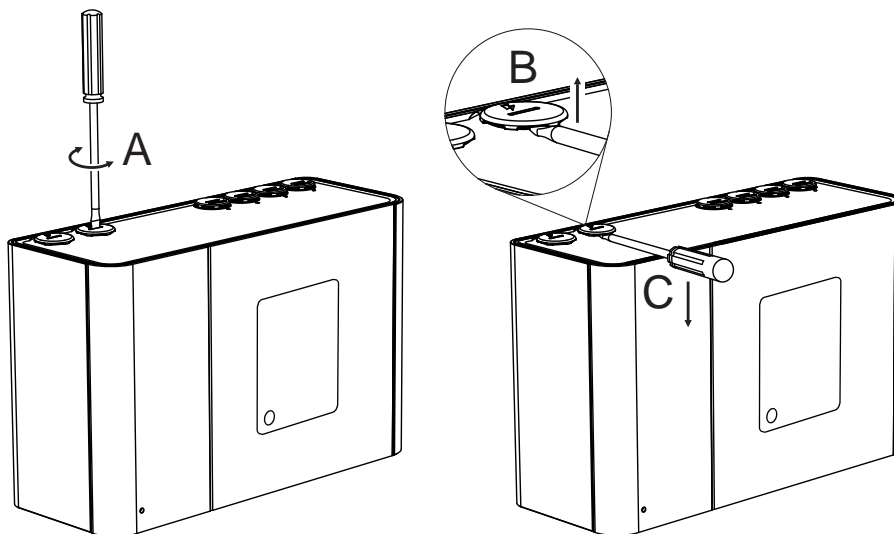

Figure 4-2: Remove Cable and Pipe Inlet Plugs

4.2 Mounting

The VEP-A10-P detector can be mounted in an upright or inverted position. Do not mount the detector with a sideways orientation as shown in Figure 4-3 below.

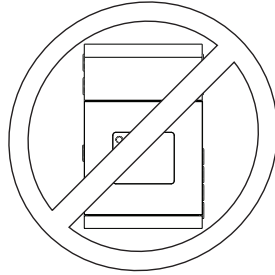

Figure 4-3: Sideways orientation

Ensure the mounting surface is flat as this allows an air tight seal to be achieved between the sampling pipe and the tapered air inlet pipes on the detector.

Ensure that there is sufficient clearance to mount the detector (Figure 4-4), noting the location of air sampling pipes and cable entry points. Due to the rigid nature of the plastic pipe, installation must provide for sufficient movement in all pipework (air inlet, air exhaust and cable pipes) to allow pipe ends to be easily fitted and removed.

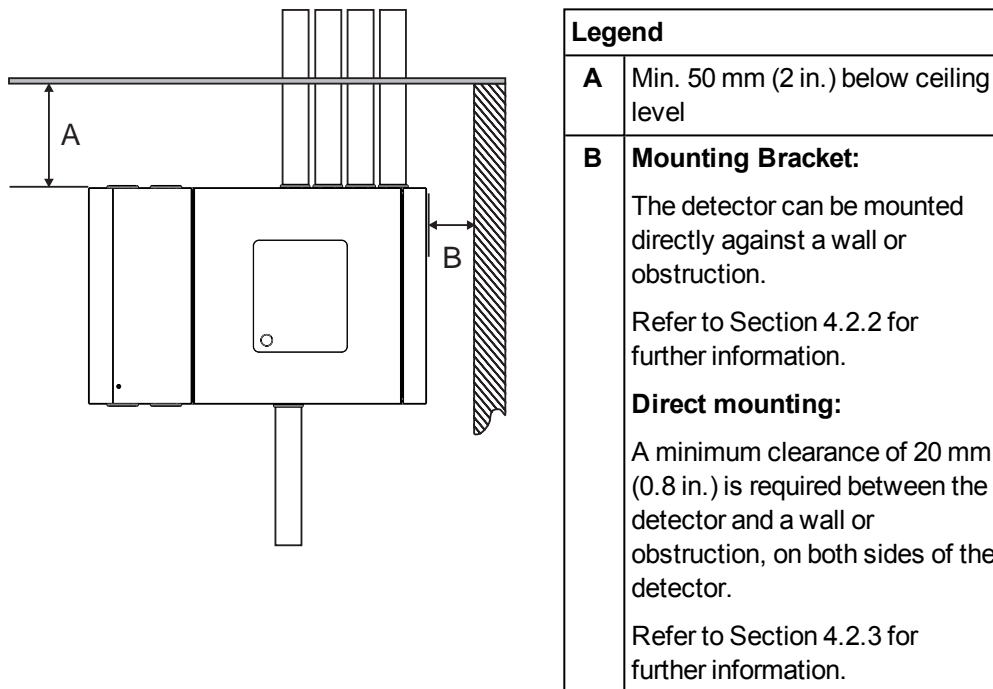

Figure 4-4: Mounting location

4.2.1 Inverting the Detector

If the pipe network design requires that the sampling pipes enter the detector at the bottom, it is possible to achieve this by inverting the detector. In this case the fascia must be inverted on the detector so that the user interface has the correct orientation. The door must be moved to the other side of the fascia to allow access to the electrical sockets and filter.

This is done as follows:

1. Place the detector on a flat surface with the back plate facing down.
2. Open the front door and remove the fascia. Refer to Sections 7.2 on page 80 and 7.4 on page 84 for further information.

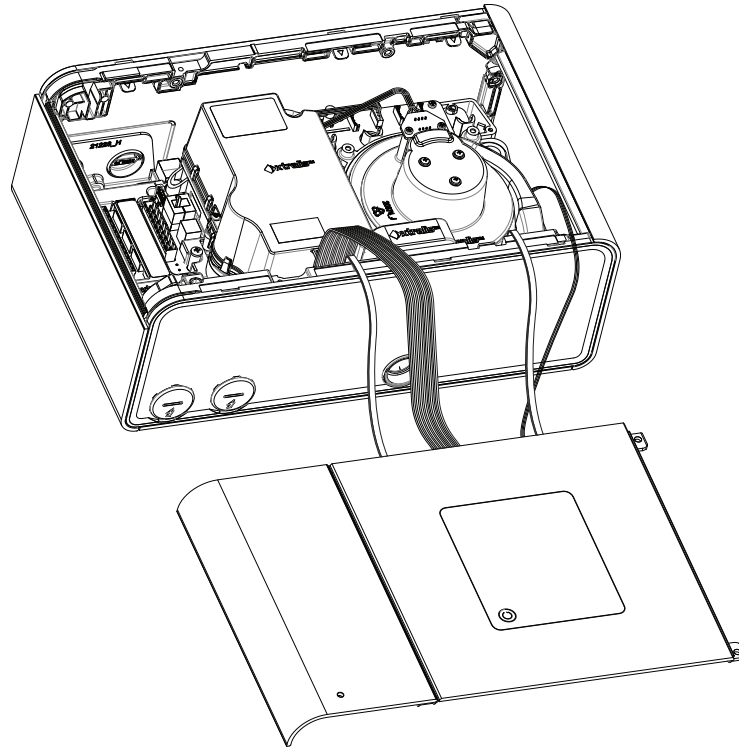

Figure 4-5: Detector with fascia removed

3. Take the top and bottom covers off. To do this, press the tabs marked A and B in Figure 4-6.

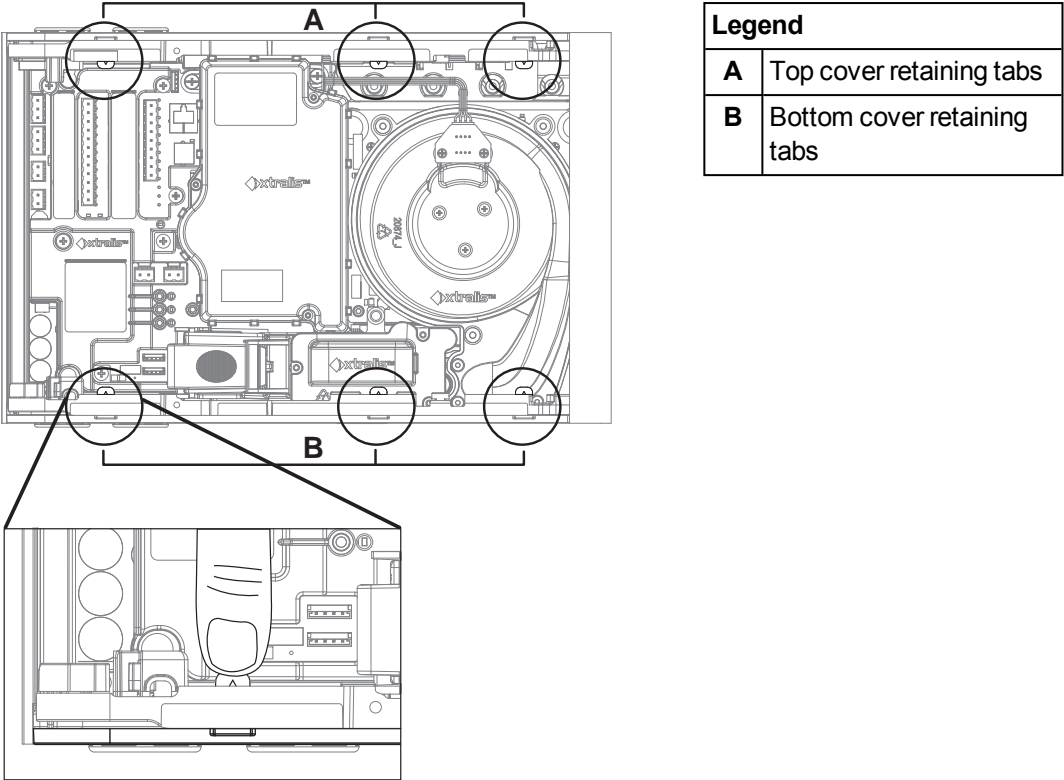

Figure 4-6: Tabs used to remove top and bottom cover

- 4. Detach the tethers, Figure 4-7 and Figure 4-8. (You can leave the cables from the detector to the fascia connected.)

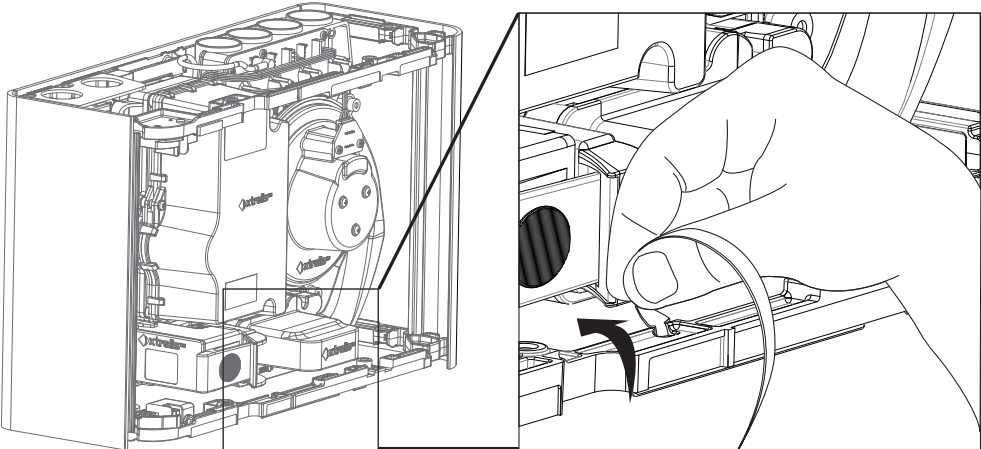

Figure 4-7: Detaching the tethers

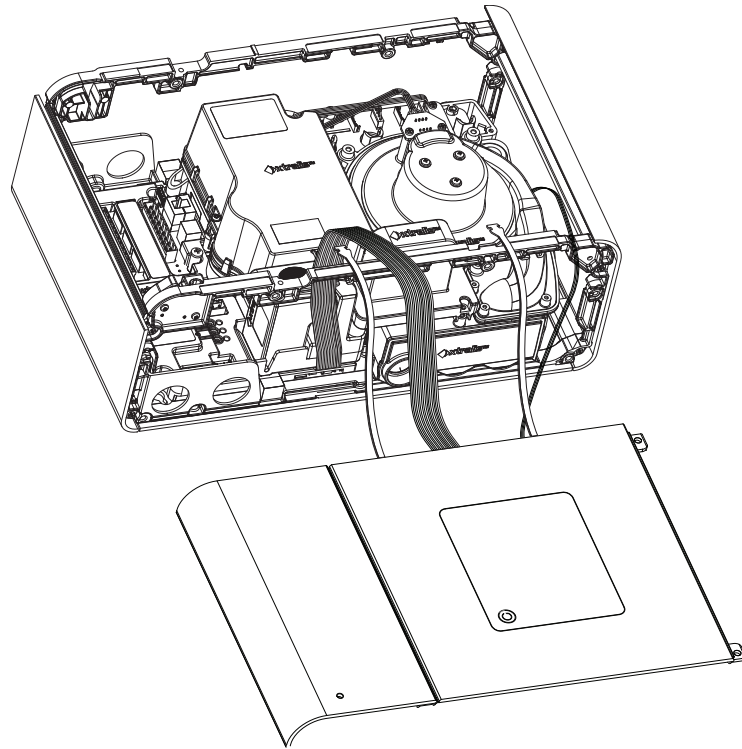

Figure 4-8: Detector with tethers detached

5. Detach the front door from the fascia by removing pin A from the hinge (Figure 4-9, Figure 4-10). Leave pin B in place – do not remove it.

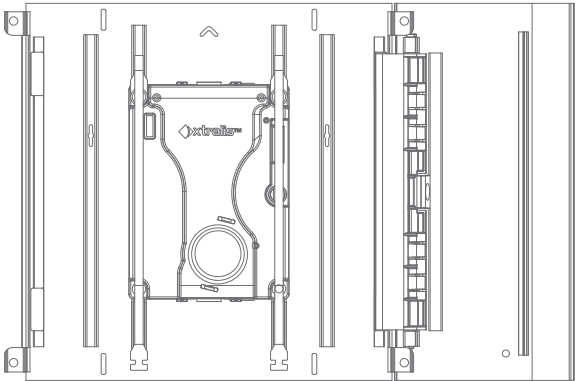
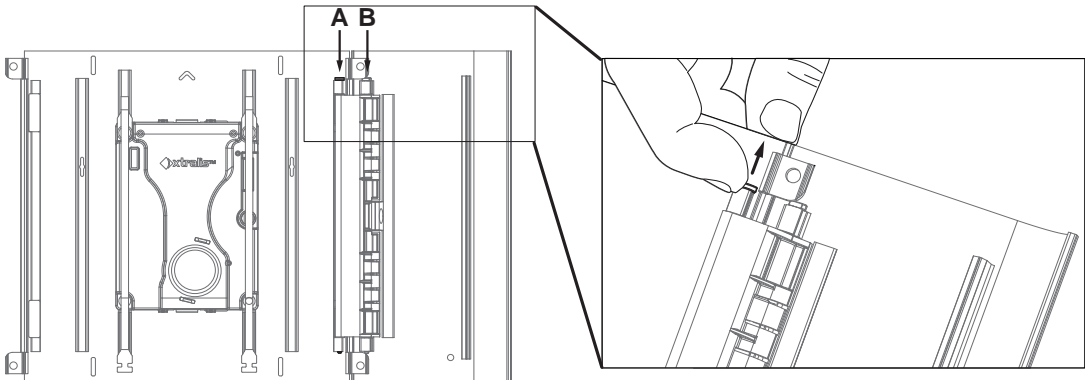

Figure 4-9: Removing door hinge pin A

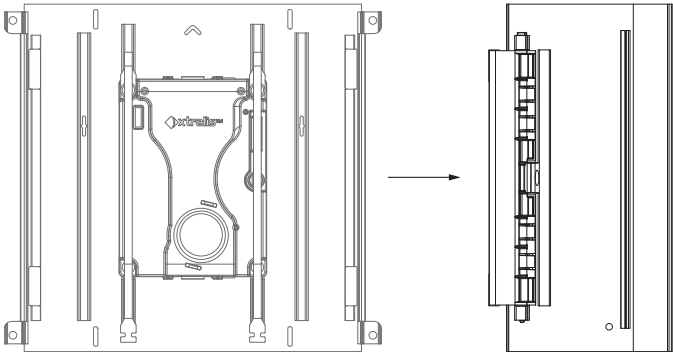

Figure 4-10: Detaching door

6. Change from setup A in Figure 4-11 to setup B by doing the following:
 - a. Leave the fascia upright.
 - b. Rotate the detector 180 degrees.
 - c. Rotate the door 180 degrees and place it next to the right side of the fascia.
7. Replace the door hinge pin. (Figure 4-12, Figure 4-13)

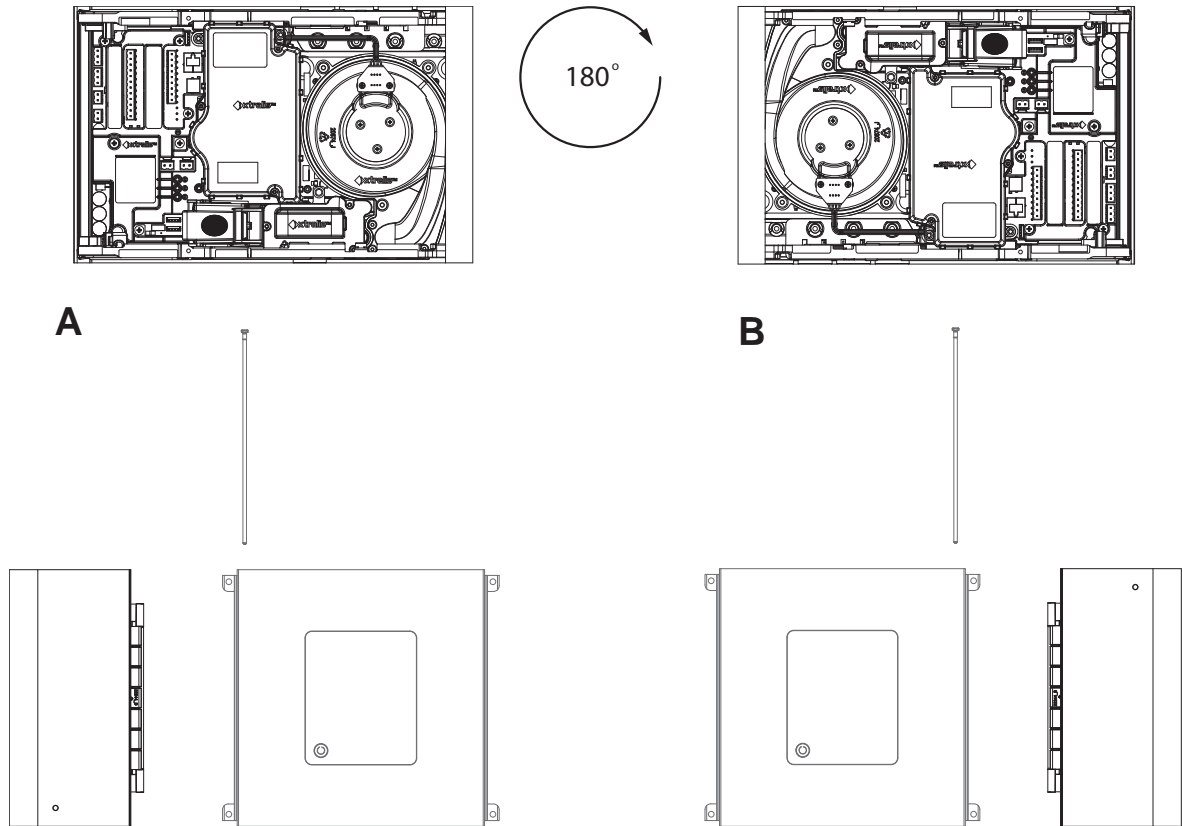

Figure 4-11: Rotate detector and door and move door to right side of fascia

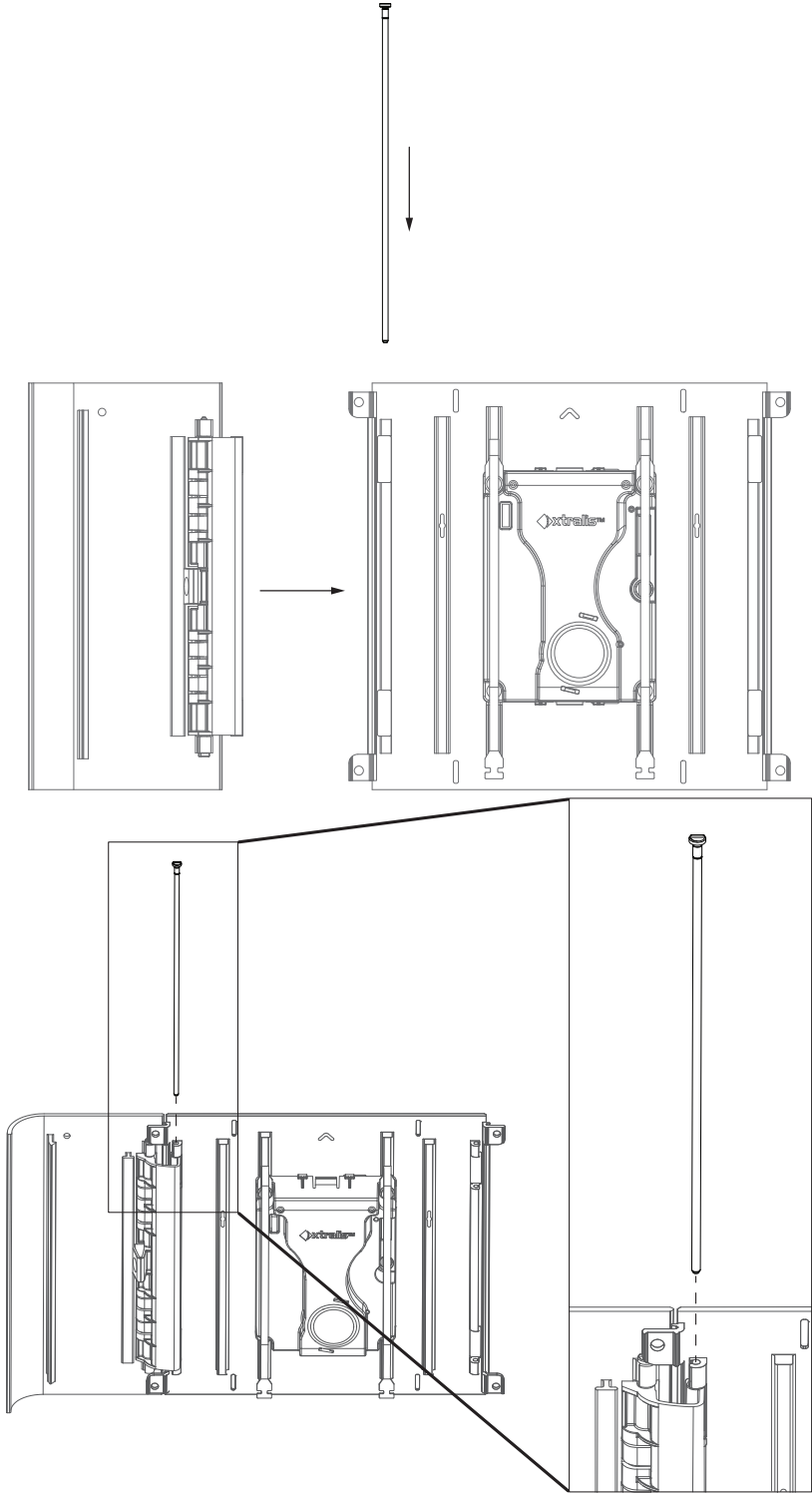

Figure 4-12: Replacing the door hinge pin - showing correct positioning of door and pin

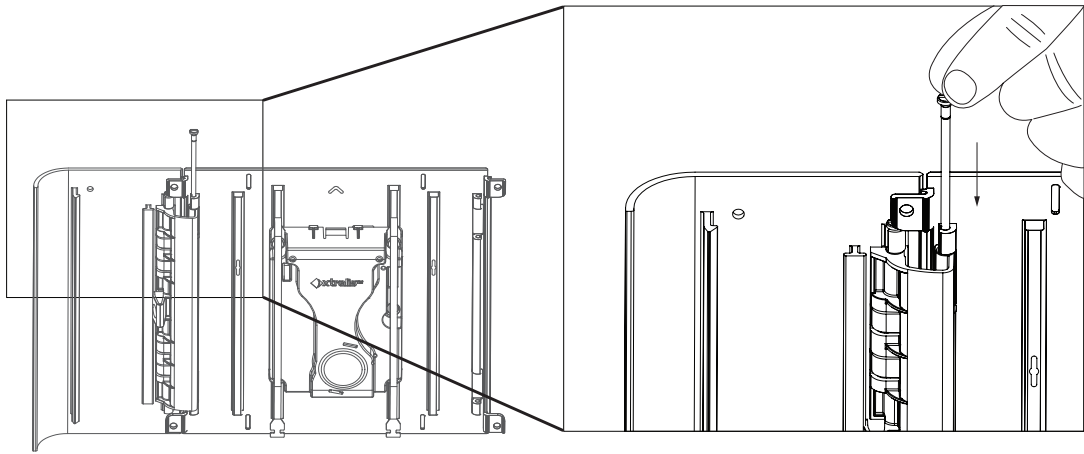

Figure 4-13: Replacing the door hinge pin

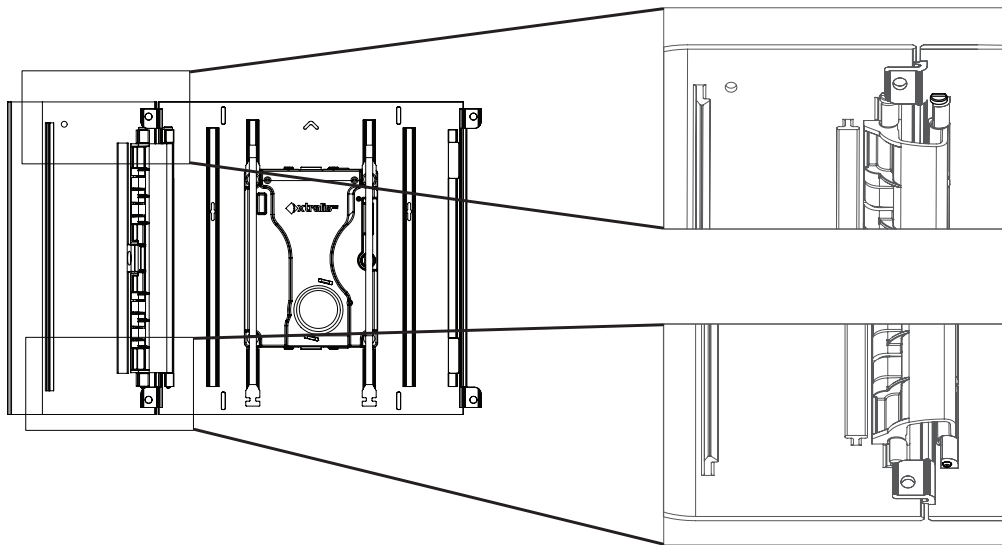

Figure 4-14: Correct positioning of door hinge pin when fully in place

8. Re-attach the tethers. Attach at the slots circled in Figure 4-15. Position the tethers in the slots and pull up as shown in Figure 4-16.

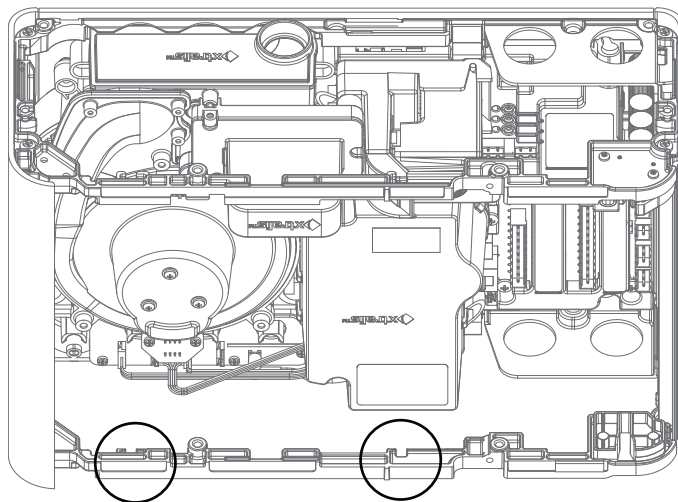

Figure 4-15: Re-attach tethers at circled positions

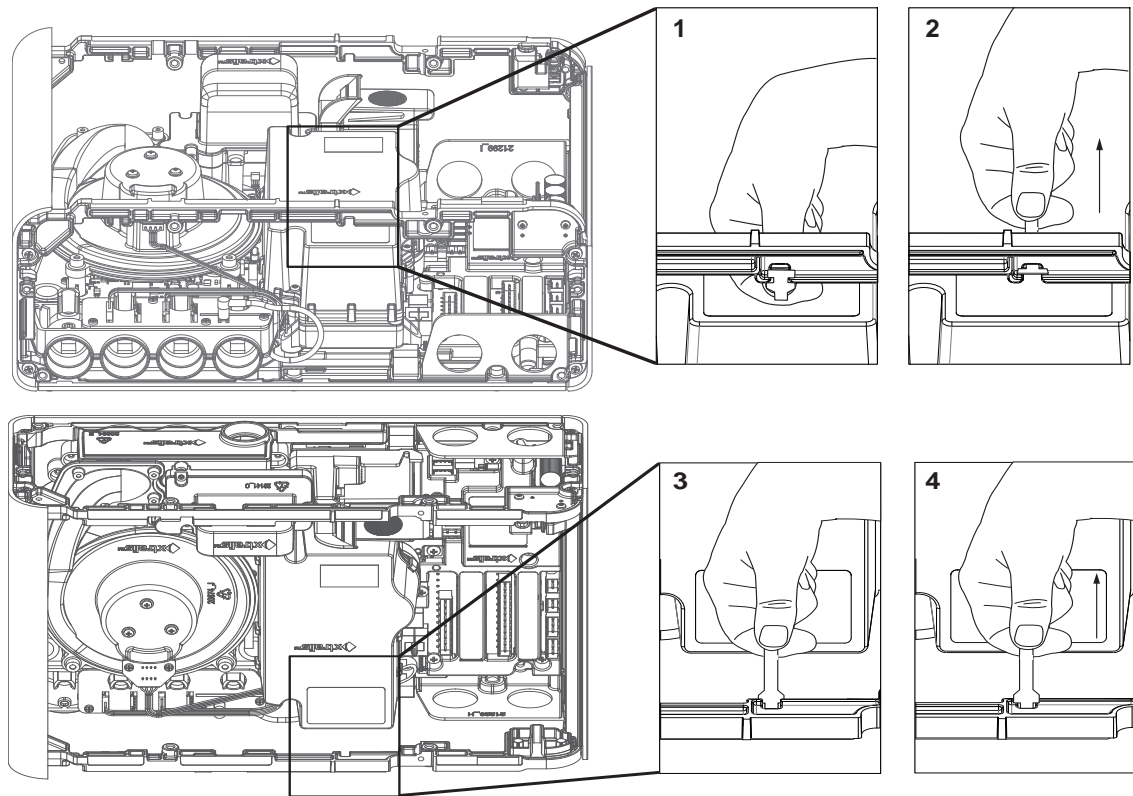
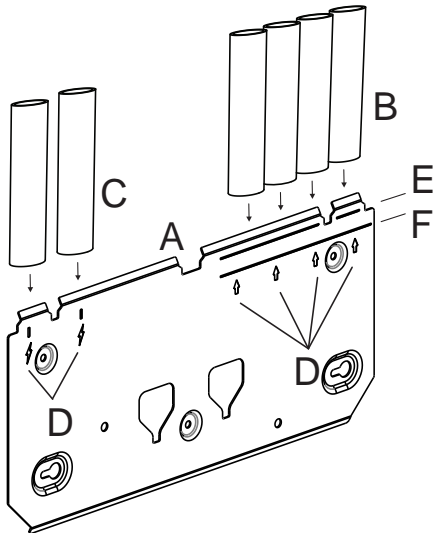

Figure 4-16: Position the tethers and pull up to attach

9. Re attach the top and bottom covers.
10. Re-attach the fascia. Re-attach to the front of the detector by tightening the two retaining screws as shown in Figure 7-8.
11. The detector is now inverted. The display should be upright while the exhaust vent is at the top and sampling pipe inlets at the bottom. The electrical connections and filter should be accessible by opening the door.

4.2.2 Mounting the Detector with the Mounting Bracket

- Position the mounting bracket (A) to allow sampling pipes (B) and electrical conduit (C) to line up horizontally with the alignment marks (D) and vertically with the appropriate pipe depth line (Figure 4-17).
 - 3/4 inch IPS pipe (1.05 inch OD) should vertically align with the top depth line (E).
 - 25mm pipe should vertically align with the bottom depth line (F).



Legend	
A	Mounting bracket
B	Sampling Pipes
C	Electrical Conduit
D	Pipe alignment marks
E	3/4 inch IPS pipe (1.05 inch OD) depth
F	25 mm pipe depth

Figure 4-17: Position Mounting Bracket in line with pipes

- Mark the mounting surface through two keyholes (B) on the mounting surface (Figure 4-18).

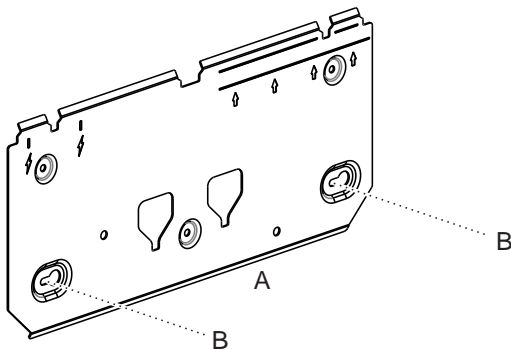

Legend	
A	Mounting bracket
B	Keyholes

Figure 4-18: Mark keyholes

- Insert two screws into the mounting surface at marked positions (Figure 4-19).
- Slide plate onto the mounting screws and tighten them with a screwdriver (B).

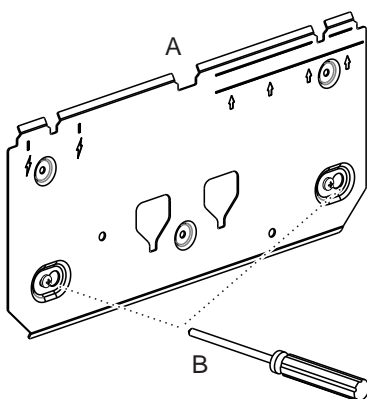

Legend	
A	Mounting bracket
B	Screwdriver

Figure 4-19: Tighten screws

5. Insert the remaining three mounting screws (B) and tighten them (Figure 4-20).

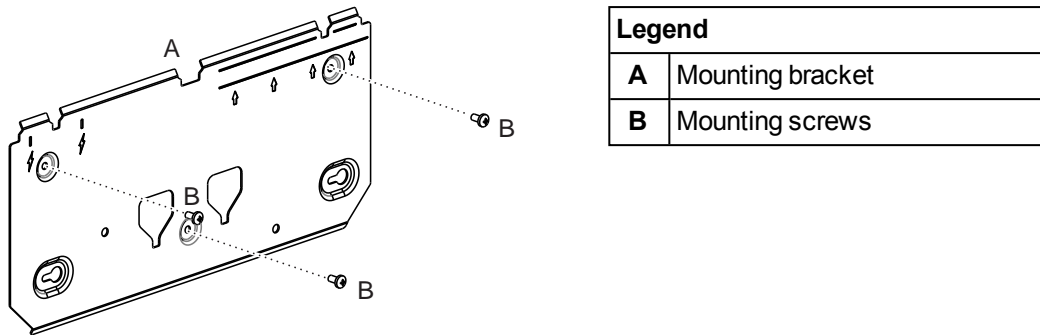

Figure 4-20: Mounting Bracket

6. Align the mounting buttons (A) on the rear of the detector with the mounting button slots on the mounting bracket, and slide the detector down until the top of the detector is flush with the top of the mounting bracket (Figure 4-21).

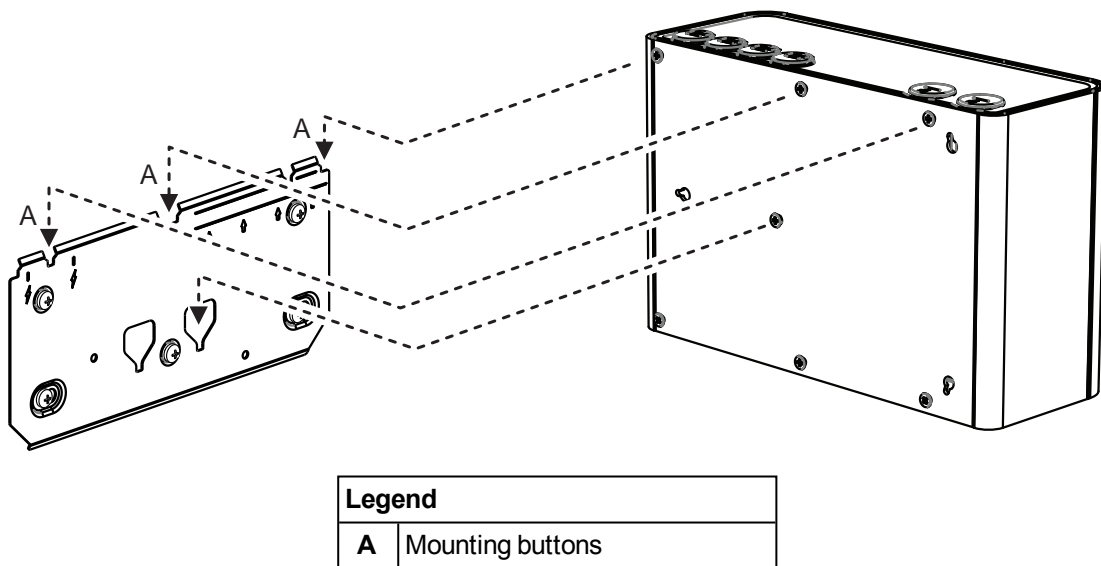

Figure 4-21: Mounting the detector

7. Open the door on the front of the detector (Figure 4-22). Refer to Section 7.2 on page 80 for further information on how to open the door.
8. Insert and tighten the locking screw (A). This secures the detector to the mounting bracket.

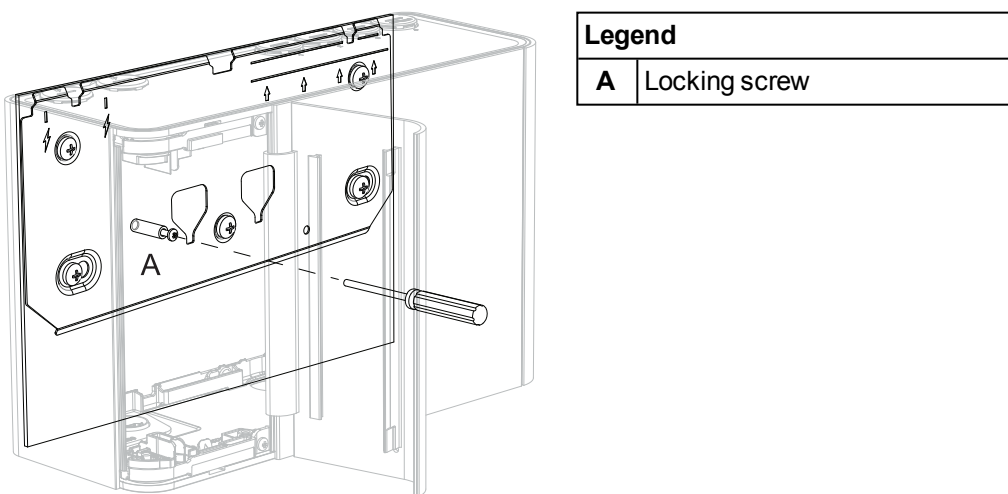

Figure 4-22: Locking Screw

4.2.3 Mounting the Detector using the Mounting Template

1. Position the mounting template to allow sampling pipes (A) to horizontally line up with the alignment marks (B) and vertically align with the appropriate pipe depth line (Figure 4-23):
 - 3/4 inch IPS pipe (1.05 inch OD) should vertically align with the top depth line (C).
 - 25mm pipe should vertically align with the bottom depth line (D).
2. Secure the mounting template to the wall.

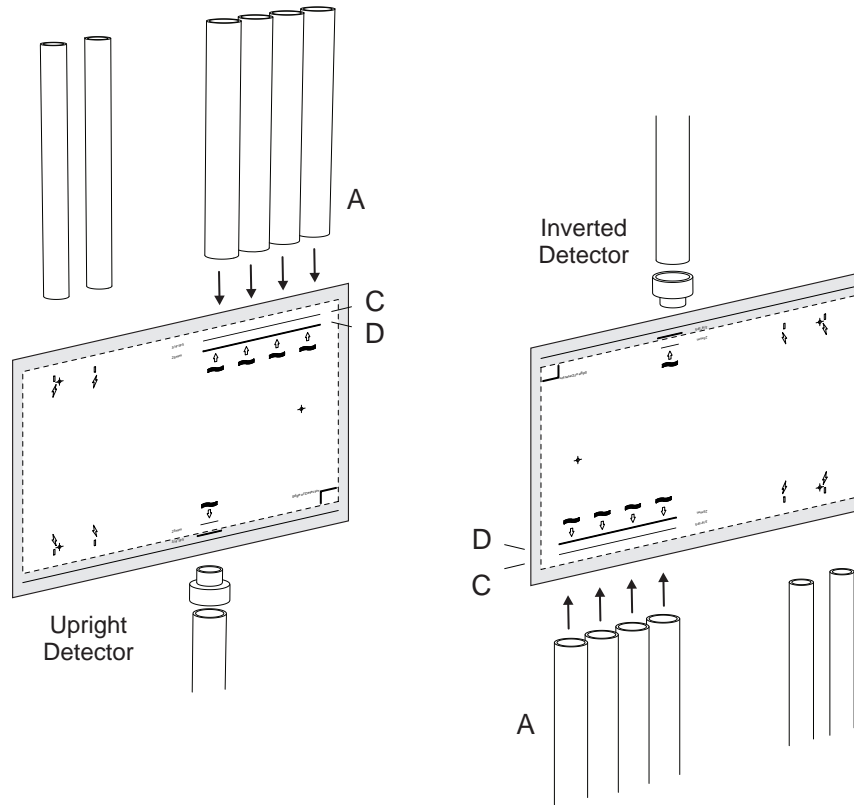

Figure 4-23: Position mounting template

3. Insert two M4 button head screws at positions A and B such that the screw head is protruding 7 mm from the wall (Figure 4-24). Drill a pilot hole at position C for later insertion of a screw at Step 12.

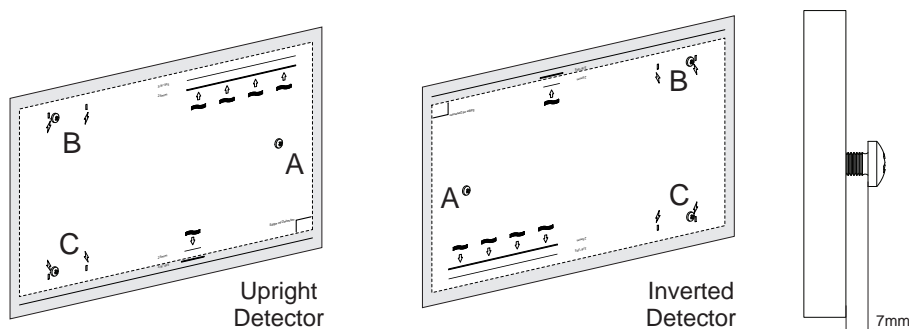

Figure 4-24: Insert mounting screws

4. Position the inlet pipes (A) on the marked center lines (Figure 4-25).
5. Cut the sampling pipes to the appropriate depth line.
6. Position the exhaust pipe (if used) (B) on the marked center line:
 - For metric pipes, cut the pipe to the inner depth line marked on the mounting template.
 - For imperial pipes, fit the pipe adaptor (C) and cut the pipe to the outer depth line marked on the mounting template.
7. Position electrical conduit (D) on the marked center lines.

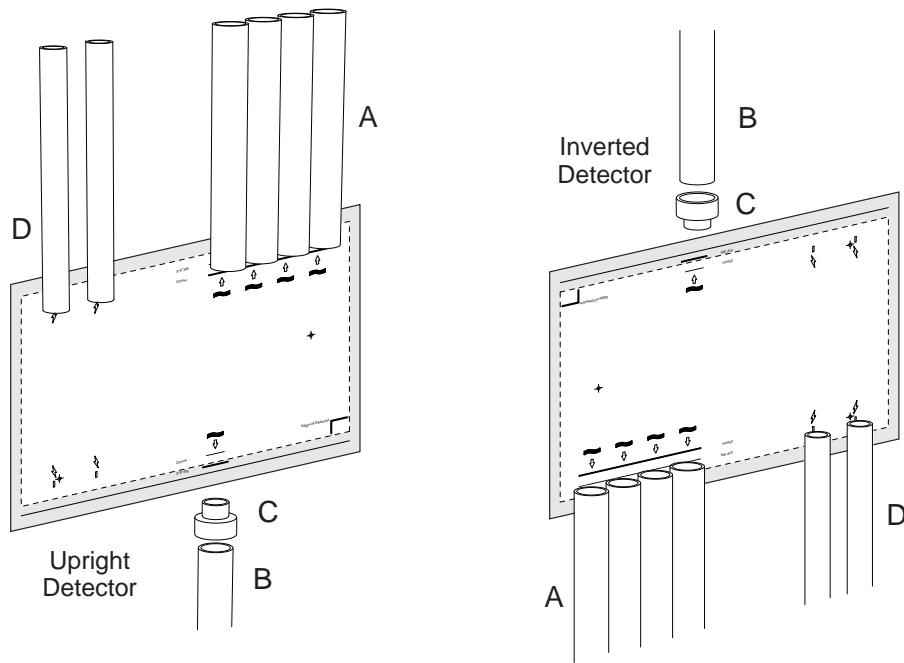

Figure 4-25: Position conduit and pipes

8. Remove the mounting template.
9. In order to allow the detector to be positioned, retract the inlet and exhaust pipes and electrical conduit.
10. Mount the detector onto the screws using the keyholes using the following steps:

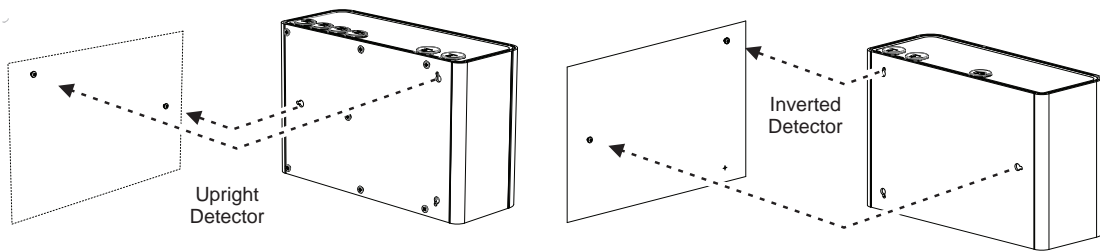

Figure 4-26: Mount the detector

- Position the right keyhole on the rear of the detector over the head of the right screw (A) (Figure 4-27).

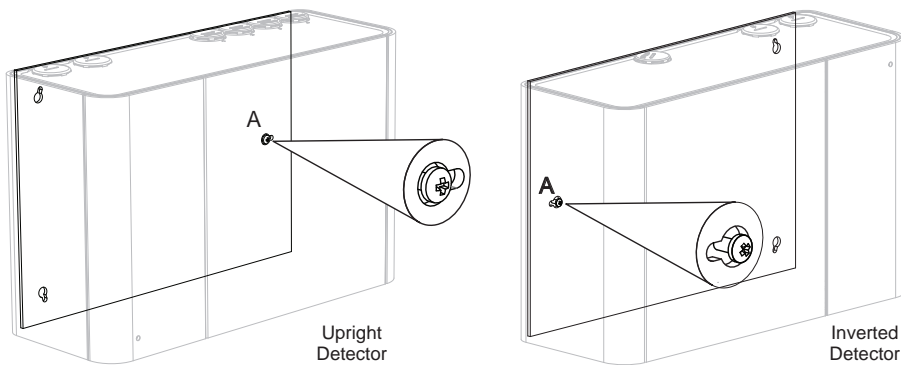

Figure 4-27: Position detector over screw

- Slide the detector to the left, or to the right for inverted detectors, to lock the detector on the screw (Figure 4-28).

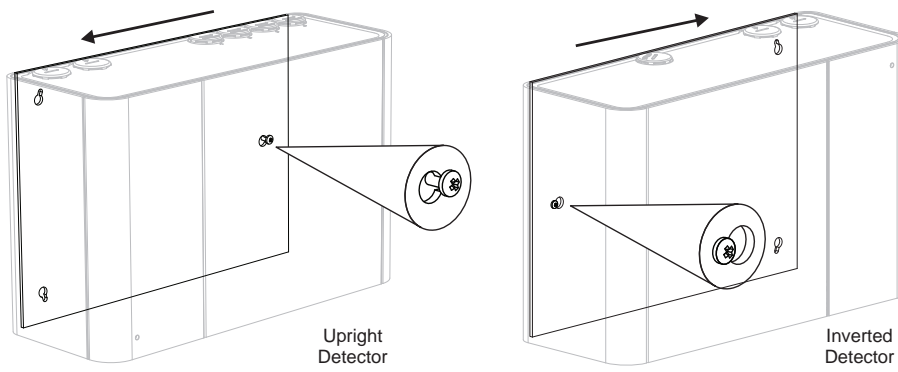

Figure 4-28: Slide detector to the left

- Rotate the detector clockwise to position the large end of the detector's top-left, or top-right for an inverted detector, keyhole over the head of screw B. Push the detector to the wall (Figure 4-29).

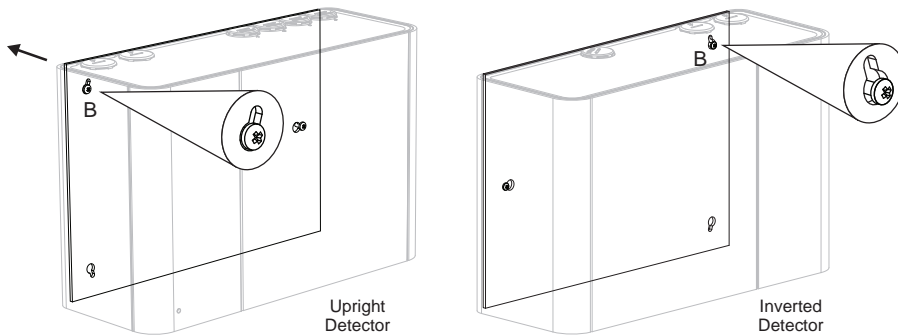

Figure 4-29: Position detector on the second screw

- Rotate the detector anticlockwise, or clockwise for an inverted detector, to lock the detector on to the screw (Figure 4-30).

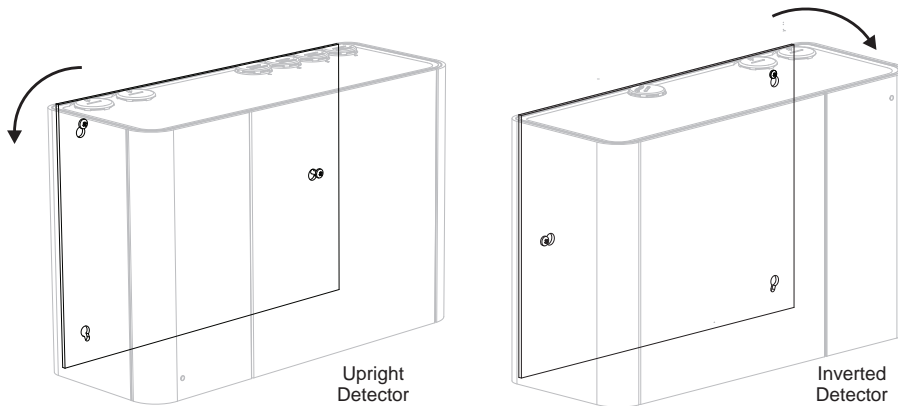

Figure 4-30: Rotate the detector

12. Insert an M4 screw at the small end of the detector's bottom-left, or bottom-right for an inverted detector, keyhole (Figure 4-31).

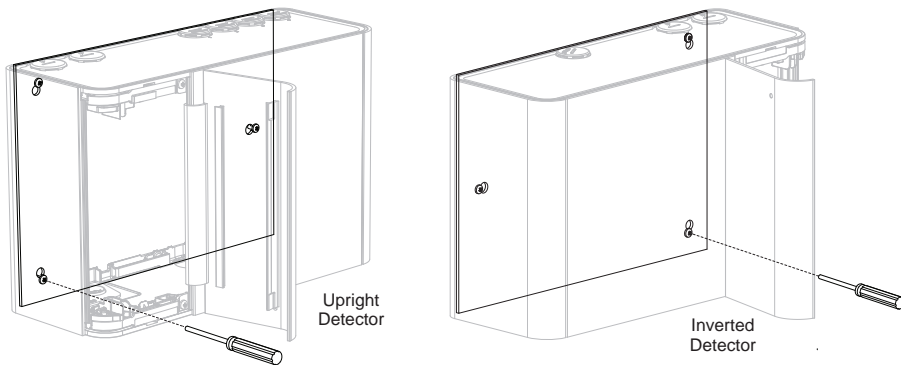

Figure 4-31: Locking screw

13. Tighten the top and bottom screws.
14. Insert the pipes and electrical conduit.

4.3 Wiring

The screw type terminals located on electrical terminals within the VEP-A10-P detector will accept wire sizes from 0.2 mm² to 2.5 mm² (24 – 14 AWG).

Refer to Codes and Standards Information for Air Sampling Smoke Detection on page iii for code specific requirements.

Refer to the VESDA-E System Design Manual for cabling details.

Note: The VEP-A10-P detector is IP 40 rated, therefore a suitable cable gland or conduit must be used to maintain the IP rating. (The IP rating is not UL tested.)



Caution: Electrostatic discharge (ESD) precautions need to be taken prior to removing the fascia from the detector in order to prevent damage to sensitive electronic components within the VEP-A10-P.



Attention : Les precautions contre le decharge electrostatique dois etre respecter avant d'ouvrir le panneau du detecteur afin de prevenir au dommage des composants electroniques a l'interieur du VEP-A10-P.

4.3.1 Cabling Inlets

The VESDA-E VEP-A10-P contains four inlets for power, relay and network cabling, located on the upper and lower sides of the detector base. The holes have a diameter of 26 mm (1.02 inch).

Note: To maintain the specified IP rating, cable glands or conduit must be used.

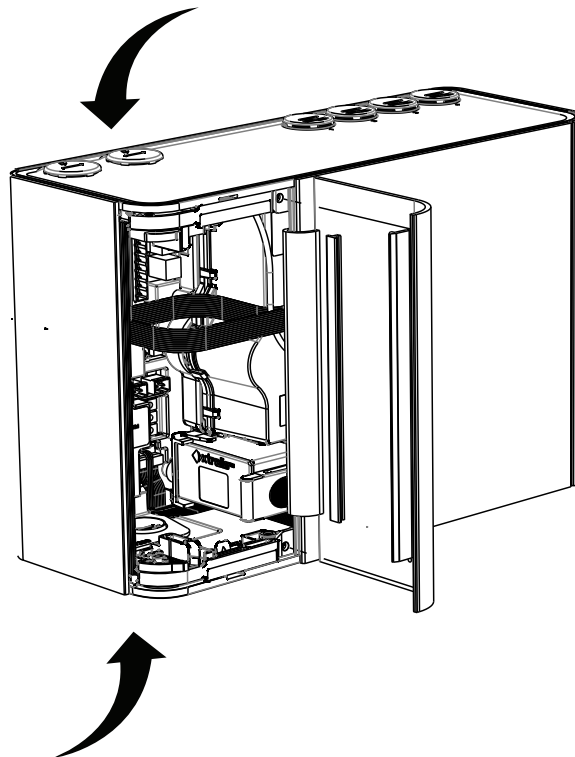

Figure 4-32: Cabling Inlets

Power to Multiple Detectors

Up to three VESDA-E VEP or VEU detectors may be daisy chained to the same power supply by connecting the PWR OUT power passthrough socket to the PWR IN socket on each subsequent detector.

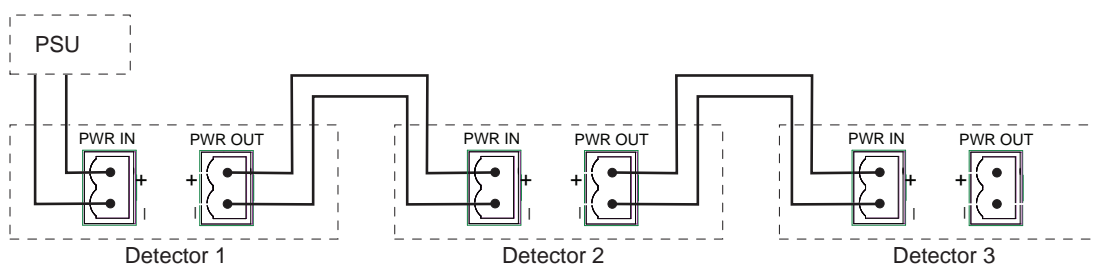

Figure 4-34: Multiple Detectors powered by a single power supply

Compliance

It is recommended that the power supply be compliant with local codes and standards required by the regional authority. For code-specific information, refer to Codes and Standards Information for Air Sampling Smoke Detection on page iii.

4.3.4 Communication Ports

The front door must be opened in order to access the communication ports. Refer to Section 7.2 for information on opening the front door and Figure 4-33 for the physical location of the ports.

Note: For all connection methods the detector also provides a gateway to all the other devices on the VESDAnet network.

USB

The USB port is used for initial configuration and local maintenance or servicing of the VEP-A10-P using a PC installed with Xtralis VSC software.

Install Xtralis VSC prior to connecting the VEP-A10-P to the PC or Laptop. This ensures that the required USB drivers are present.

Notes:

- The USB port must not be used for permanent field connection. For example, do not use a USB to Ethernet or USB to Wifi adaptor to connect the detector to a LAN using USB.
- Refer to the Xtralis VSC documentation for operating system compatibility information.

Ethernet

The Ethernet port is used for permanent network connection to the VEP-A10-P. An Ethernet lead can be routed through the cable entry ports and plugged into the Ethernet port.

Use a standard Ethernet lead when connecting the VEP-A10-P to a network switch, router or directly to a PC or laptop.

WiFi

The WiFi module provides wireless connection of the detector to the building network for the purpose of configuration and secondary monitoring.

4.3.5 VESDAnet

VESDAnet is a bidirectional data communication network between connected VESDA-E devices. VESDAnet connectivity is available on the VEP-A10-P detector. Refer to Section 2.6 for further information.

It is recommended that RS 485 (Belden 9841 - 120 Ohm) twisted pair cables be used for including the devices in the network.

The network cables are terminated at the VESDAnet A and B Terminals. Cabling from one VESDA-E device is brought into the detector at one terminal and looped out to another device on VESDAnet from the other terminal.

Notes:

- The polarity of the data wires must be maintained throughout the network.
- In order for the detector to be able to detect ground faults on the VESDAnet wiring, the Ground Reference Terminal (Figure 4-33) must be connected to the local ground.

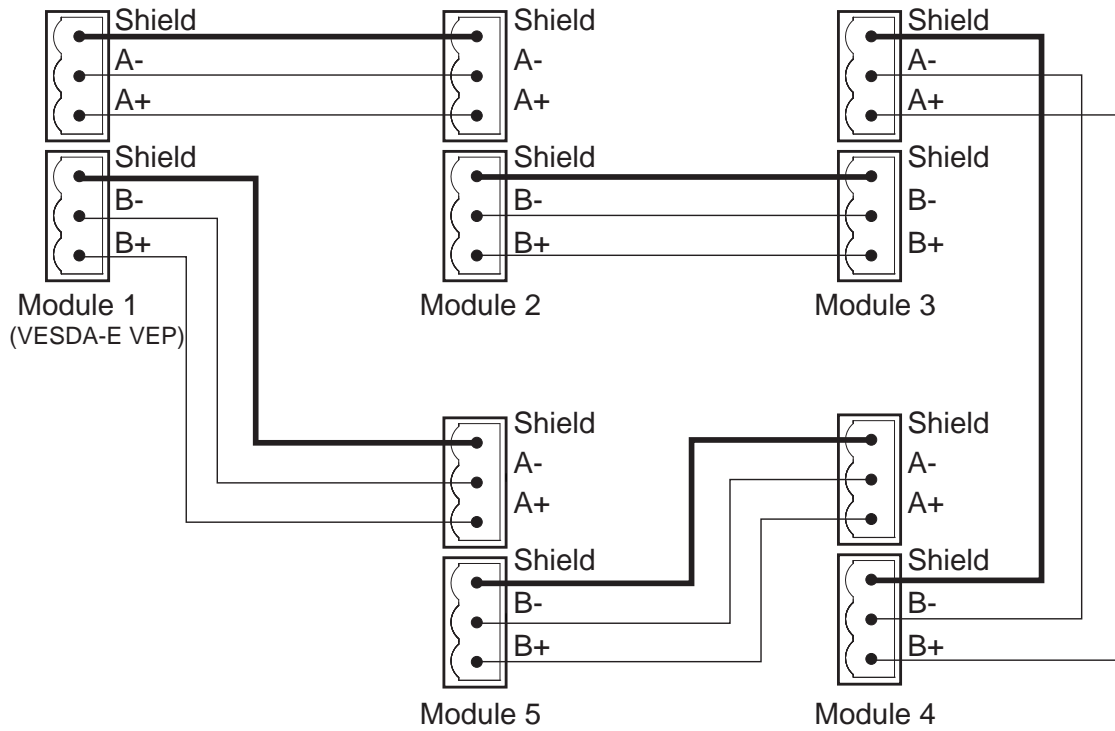

Figure 4-35: Example closed loop VESDAnet network

The VESDA-E VEP-A10-P detector is shipped with the VESDAnet A and B terminals looped. Remove the A and B links prior to connecting the detector to the VESDAnet. If the detector is not to be networked with other devices, then do not remove the A and B links.

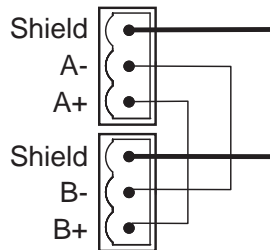

Figure 4-36: Closed loop for standalone detectors with VESDAnet capability

Note: Refer to the VESDA-E Communications Guide for further information.

4.3.6 Relays

The relays, located on the main processor card, interface to the Fire Alarm Control Panel (FACP) to communicate faults, alarms and disabled states. The relays can be programmed using Xtralis VSC. Relays 3 and 6 are permanently set for Urgent Fault and Fire 1 respectively. Table 4-22 below illustrates the default assignments of functions (conditions) to relays and summarizes the default behavior of each relay. Section 5.5.10 describes how to configure the relay behavior using Xtralis VSC. It is possible to assign more than one condition to a relay.

Fire 1 Relay

If a detector relay is to be used to signal fire alarm to the Fire Alarm Control Panel (FACP) then the Fire 1 relay must be used.

Fault and Fire 1 Relay Terminals

The Urgent and Minor Fault relays are energized during normal operation while the Fire 1 relay is only energized when a Fire 1 is detected. The operation of the relays are summarized in the following table.

Table 4-1: Typical Relay Operation

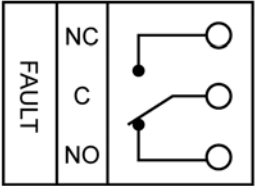
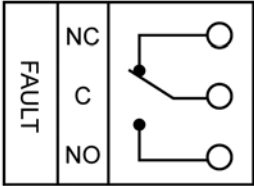
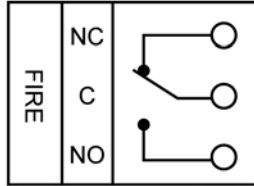
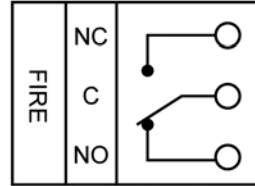
URGENT FAULT Relay		All Other Relays	
No Fault (Energized)	Fault or unpowered state	No Fire (De-energized)	Fire
			

Relay Assignments and Behaviour

- Relays 1, 2, 4, 5 and 7 are fully configurable. For example, Relay 5 could be configured to de-energize on Alert
- Relays 3 and 6 are fixed to Urgent Fault and Fire 1 respectively. These relays may be assigned additional conditions.

Table 4-2: Default Relay Assignments

Relay #	Default Assignment	Default to Normally Energized	Description for default configuration	Configurability
1	Disable (Isolate) and Standby	No	Energizes when an operator disables (isolates) the detector. Also energizes when the operator puts the detector into Standby mode.	Fully configurable
2	Minor Fault	Yes	De-energizes when a Minor Fault is detected.	Fully configurable
3	Urgent Fault	Yes	De-energizes when an Urgent Fault is detected. Note that Relay 3 is fixed Normally Energized in order to ensure that a fault will be signaled when power to the VEP-A10-P is removed. See Table 4-1.	Urgent Fault cannot be removed. Other conditions can be added. Fixed Normally Energized
4	Alert	No	Energizes when the Alert alarm is initiated.	Fully configurable

Table 4-2: Default Relay Assignments (continued...)

Relay #	Default Assignment	Default to Normally Energized	Description for default configuration	Configurability
5	Action	No	Energizes when the Action alarm is initiated.	Fully configurable
6	Fire 1	No	Energizes when the Fire 1 alarm is initiated.	Fire 1 cannot be removed. Other conditions can be added.
7	Fire 2	No	Energizes when the Fire 2 alarm is initiated.	Fully configurable

4.3.7 Unmonitored General Purpose Input (GPI)

The Unmonitored GPI is a programmable input which can be configured to initiate a number of different actions, including, by default, a Remote Reset function. Refer to Section 5.5.9 on page 68 for further information.

A voltage input of between 5V and 30V signals GPI ON. Less than 2V signals GPI OFF. The input is isolated from the system by an opto-coupler device.

4.3.8 Monitored General Purpose Input (GPI) Wiring

The monitored GPI senses contact closure and is configurable to initiate the same actions as the unmonitored GPI. "Remote Reset" is the default setting. A closed contact signals GPI ON and open contact signals GPI OFF.

A 10K end of line resistor is used to allow the detector to monitor for open circuit faults in the wiring from the detector to the contact. Refer to Section 4.3.11 for information on correct wiring of the End of Line resistor.

4.3.9 Typical Wiring to Fire Alarm Control Panel (FACP)

The diagram below shows the correct way to wire VESDA-E detectors to a conventional fire alarm control panel (FACP).

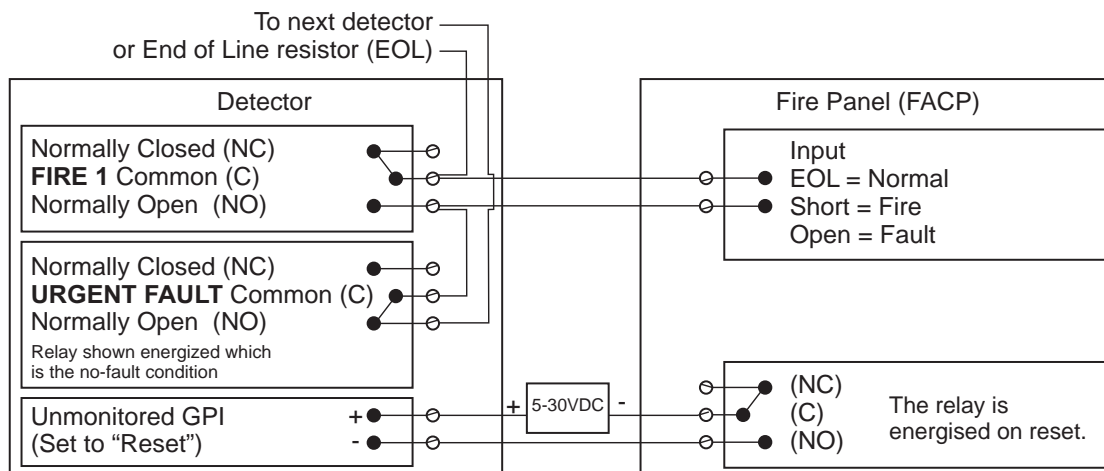

Figure 4-37: Typical wiring to a fire panel with EOL

4.3.10 Typical Wiring to Addressable Loop Module

This wiring example is for wiring VESDA-E detectors to a typical third party Input/Output Loop module 3 inputs 1 output.

Note: These are example drawings. Refer to the appropriate product manual for the exact wiring details of the third party equipment.

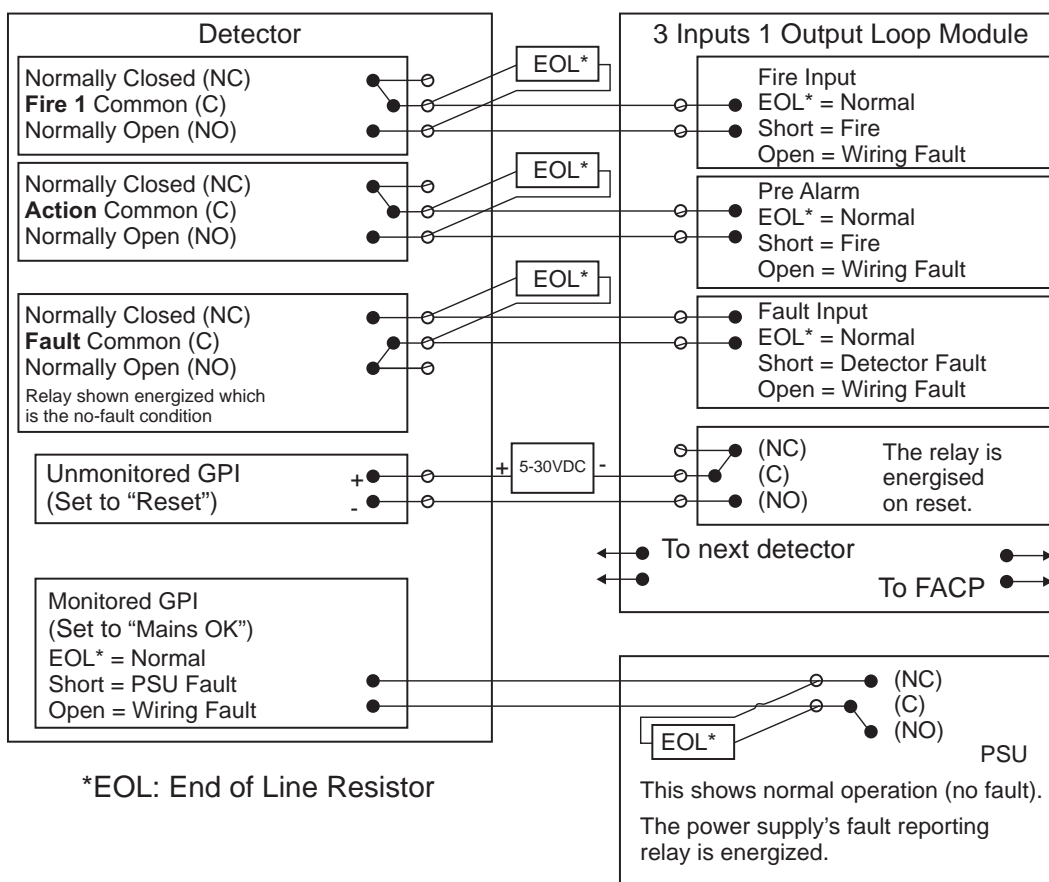

Figure 4-38: Input/Output Loop Module with EOL

4.3.11 Typical Wiring for Monitored GPI for PSU Monitoring

The diagram below shows the correct way to configure power supply monitoring. It also shows where an End Of Line (EOL) resistor is correctly installed. Refer to Section 4.3.8 on page 41 for further information.

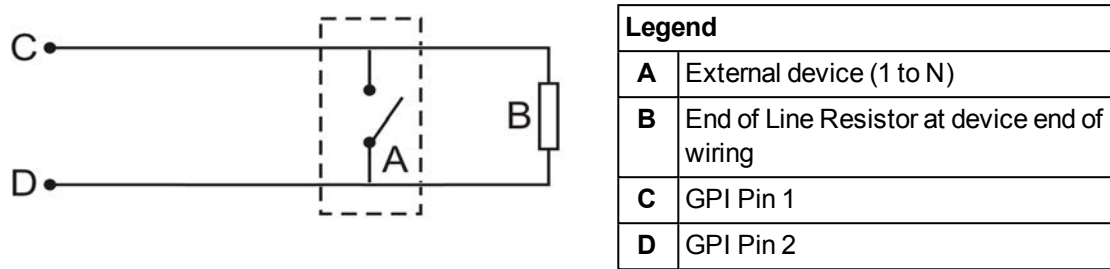

Figure 4-39: Power Supply Connection Diagram

4.3.12 Specify Backup Battery

In the event of a mains power supply disruption, the VEP-A10-P detector runs on a backup battery located in the external power supply (the power supply must be compliant with local fire protection codes and standards). The size of the battery is determined by:

- local codes and standards
- the total power required by the system
- back up time required
- allowance for reduction in capacity with age
- expected temperature variations

Note: It is recommended that batteries be inspected and changed as per manufacturer’s specifications or as per local codes and standards.

To facilitate the calculation of the backup battery size, a Battery Calculation Sheet is included below.

Table 4-3: Calculating the size of backup battery

Equipment	Normal loads @ 24 V DC (Backlight off)			Full alarm load @ 24 V DC (Backlight on)		
	Load (A)	Qty	Total	Load (A)	Qty	Total
Detector set to Fan Speed 1	0.34			0.43		
Detector set to Fan Speed 5	0.42			0.48		
Other 24V Loads		Total (A)			Total (A)	
			X			X
	Normal Hours			Alarm Hours		
			=			
	Normal Capacity			Alarm Capacity		
				Total Capacity = Normal + Alarm		
				Multiply by battery factor X1.25		

4.4 Powering Up

After installing the detector it is necessary to power up the system. The power up sequence lasts approximately 15 seconds.

The VEP-A10-P detector does not have a power switch i.e it is an "always on" device which is activated by applying powered cabling to the power input terminal on the main board (Figure 4-33). This process must only be performed by Xtralis accredited personnel.

If the system fails to power up, check all power wires are secured to their terminals and that the polarity is correct.

On power up:

- The Power LED illuminates and the detector runs a series of self-diagnostic tests.
- If there is a fault, the Fault LED illuminates. To identify the fault, check the Active Event List for the detector using Xtralis VSC.
- The aspirator starts up and air may be felt flowing out of the exhaust port.

It is normal for the detector to display airflow faults immediately after the first power up and until the air flow normalization step is done. Reset the detector by pressing the reset button on the front of the unit. This will unlatch the relays and turn off the Fault LED. Any remaining faults will cause the Fault LED to illuminate again. Proceed with the preliminary system check.

4.5 Installation Checklist

Site Name	
Address	
Detector Serial Number(s) and Date of Manufacture	
Name of Installer	
Signature	
Date	

Perform the following checks listed below to ensure that all the necessary items are completed before handing over to a commissioning engineer.

Installation Checks	Done (Y/N)
The detector is securely locked onto the mounting bracket (if in use). Refer to Figure 4-22 on page 29 for further information.	
The sampling air pipes are firmly connected to the air inlet ports. Ensure that the pipes are NOT glued.	
The power supply wiring has been connected to the detector.	
If required, the end of line resistor for the monitored GPI has been connected. Refer to Section 4.3.11 on page 43 for further information.	
The alarm and fault relay output terminals of the detector have been connected to the fire panel.	
The adhesive tape has been removed from the exhaust port. Ensure that the exhaust pipe (if fitted) is NOT glued.	
The protective film has been removed from the display.	
The air sampling pipework has been installed and checked as per the site plans.	

4.6 Preliminary System Check

A preliminary system check is required after installing the VEP-A10-P detector, before it is commissioned for use.

To perform the preliminary system check:

- Power up the detector by connecting the power supply to the Power In terminal.
- Check that the display is functioning.
- Check that the aspirator is functioning by determining whether air is being expelled from the exhaust port.

This page is intentionally left blank.

5 Configuration

This chapter describes a number of configuration options, user functions and security features of the VEP-A10-P detector that the installer and users must be familiar with. These include:

- defining connections and connecting to the detector
- security
- detector commands
- configuration options
- relay options
- GPI functions
- default settings

The VEP-A10-P detector is initially configured using Xtralis VSC software installed on a PC directly connected to the USB port. It is necessary to connect to the detector in order to configure it. The procedure for connecting to the detector is described in Section 5.1.1 below.

5.1 Communication between Xtralis VSC and the detector

In order to allow communication between Xtralis VSC and the detector, the following steps must be performed:

1. Define a USB Connection Profile and then connect to the detector using USB (See Sections 5.1.1, 5.1.2 and "Adding a USB Connection" below).
2. If using Ethernet or WiFi as a permanent connection method, then:
 - configure the respective parameters in the detector, including the authentication password.
 - create a connection profile for Ethernet or WiFi as required.
 - connect to the detector.

USB is used for initial configuration, however it must not be used for permanent connection. Permanent connection for secondary monitoring must only be done with Ethernet or WiFi.

For example, the installer would connect directly to a VEP-A10-P using the USB port with a laptop running Xtralis VSC in order to configure the detector to enable Ethernet or WiFi, the parameters of which could be unique for each installation. A connection profile would need to be defined for the temporary USB connection, and then for the permanent connection using VESDAnet, Ethernet or WiFi.

Note: Refer to the VESDA Communications Guide for further information.

5.1.1 Defining Connection Profiles in Xtralis VSC

There are multiple ways to connect to a VEP-A10-P detector. Each connection method requires a range of information. This information is saved in a connection profile in the Xtralis VSC Connection Manager, which subsequently enables the user to quickly connect to the detector.

5.1.2 Connection Profile for a Detector

To define a connection to a VEP-A10-P detector connected to the PC or laptop via USB, Ethernet or WiFi, follow this procedure:

1. In Xtralis VSC, select **Connection | Manager** from the menu system.
The Connection Manager dialog is displayed (Figure 5-1).

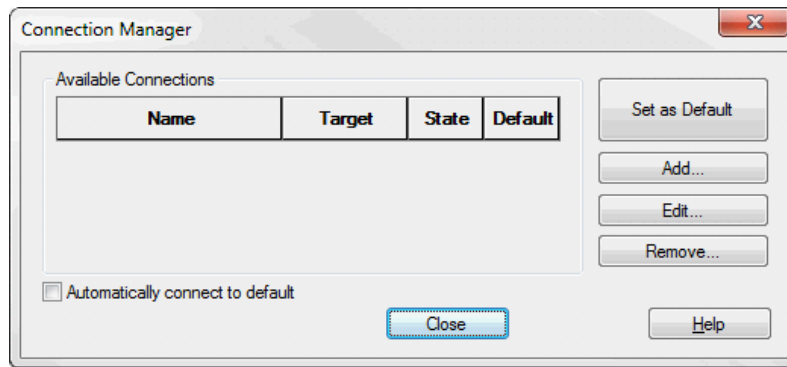

Figure 5-1: Connection Manager

2. Select **Add**.
The Add Connection dialog is displayed (Figure 5-2).

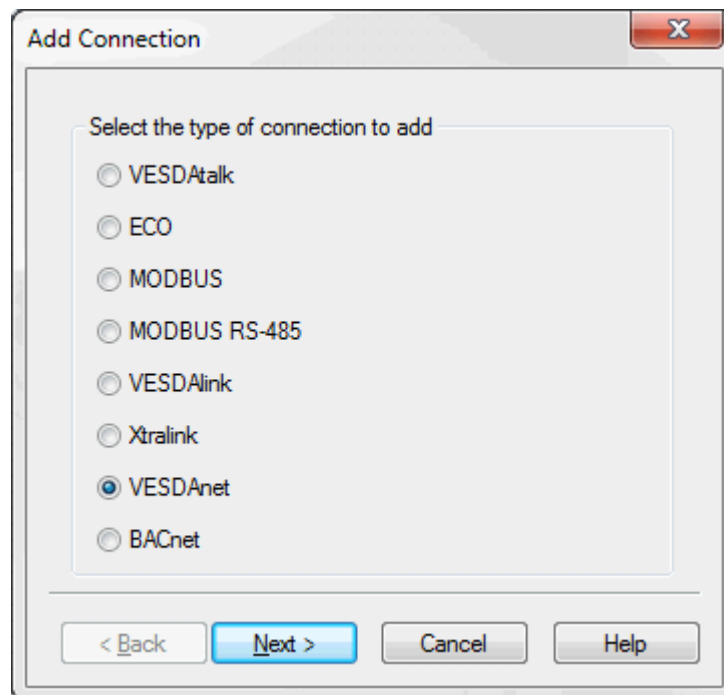

Figure 5-2: Add Connection

3. Select the VESDAnet connection option, then select **Next**.

Adding a USB Connection

1. Select **USB**, then select **Next** (Figure 5-3).

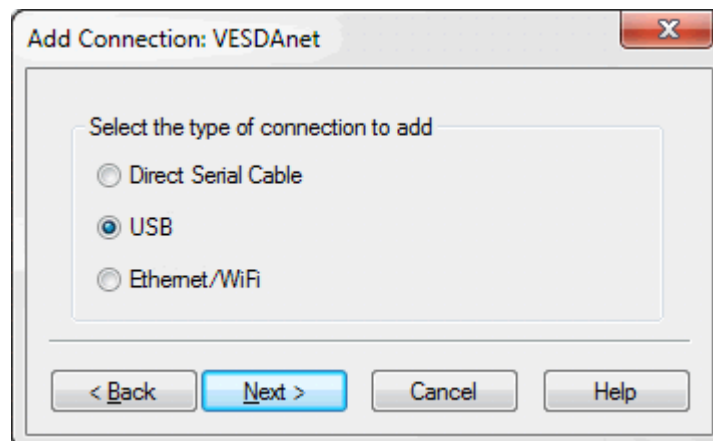

Figure 5-3: Select USB

2. Enter a unique name for the Connection or accept the pre-generated name, then select **Finish** (Figure 5-4).

The screenshot shows a dialog box titled "Add Connection: VESDAnet". It has a close button (X) in the top right corner. The main area is divided into two sections. The top section is labeled "Save the connection as" and contains a text input field with the name "VESDAnet on Any USB Port" and an "Advanced >>>" button. The bottom section is labeled "Details" and shows "Protocol: VESDAnet Route" and "VNRRoute USB Layer". At the bottom of the dialog are four buttons: "< Back", "Finish", "Cancel", and "Help".

Figure 5-4: Enter a Connection Name

Adding an Ethernet or WiFi connection

1. Select **Ethernet / WiFi**, then select **Next** (Figure 5-5).

The screenshot shows a dialog box titled "Add Connection: VESDAnet". It has a close button (X) in the top right corner. The main area is labeled "Select the type of connection to add" and contains three radio button options: "Direct Serial Cable", "USB", and "Ethernet/WiFi". The "Ethernet/WiFi" option is selected. At the bottom of the dialog are four buttons: "< Back", "Next >", "Cancel", and "Help".

Figure 5-5: Select Ethernet

2. Enter the IP address of the detector. Enter the password that has been set for Ethernet and WiFi authentication. Select **Next** (Figure 5-6).

Note: The IP address and password of the detector is configured in the Ethernet or WiFi options section during initial setup with a USB connection. Refer to Section 5.5.3 on page 61 or 5.5.4 on page 63 for further information.

The screenshot shows a dialog box titled "Add Connection: VESDAnet". It has a close button (X) in the top right corner. The main area contains three text input fields: "Remote Device IP Address" with the value "192 . 168 . 10 . 249", "Port" with the value "22094", and "Password" which is empty. At the bottom of the dialog are four buttons: "< Back", "Next >", "Cancel", and "Help".

Figure 5-6: Enter IP Address

3. Enter a unique name for the Connection or accept the pre-generated name, then select **Finish** (Figure 5-7).

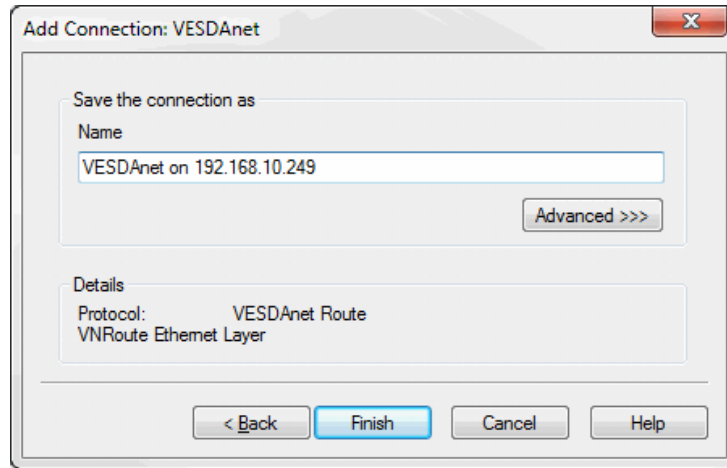

Figure 5-7: Enter a Connection Name

5.2 Connecting to the Detector

Once a Connection Profile has been defined, it is possible to connect to the VEP-A10-P detector using the following methods:

5.2.1 Connecting to a detector via USB

Direct connection between the detector and the PC installed with Xtralis VSC can be made using a Type A to Type B USB interface lead.

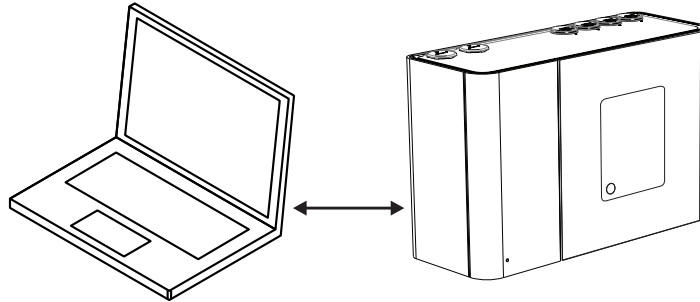

Figure 5-8: Connecting to a detector via USB

Connect to a detector using Xtralis VSC

1. If required, define a connection, as described in Section 5.1.2 on page 49.
2. Select **Connection > Connect and View**.
3. If the previously defined connection profile is set as the default connection, select OK, otherwise select Details, then select the required USB connection from the list of available connection profiles and select OK.

5.2.2 Connecting to a detector via Ethernet

Connection using Ethernet cabling between the detector and the PC installed with Xtralis VSC can be made using a router or switch (Figure 5-9), or directly between the two devices. Complex networks are beyond the scope of this document.

For a successful connection, Ethernet connectivity must be enabled within the detector, the detector must have an IP address, and an authentication password must be set. Configuration procedures for these requirements are detailed below.

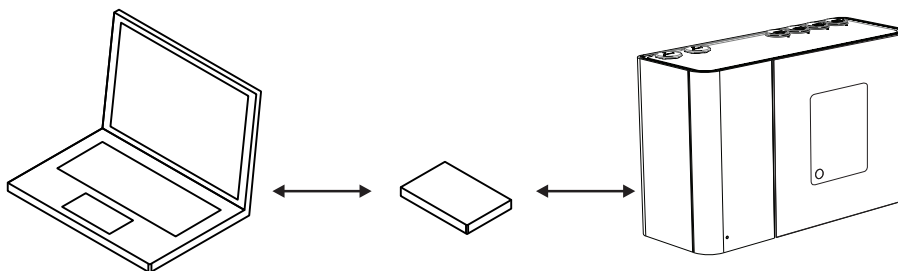

Figure 5-9: Connecting to a detector via Ethernet using a router or switch

Enabling Ethernet Connection

The Ethernet connection method only needs be configured once, and then edited if there is a change to any of the relevant building network connection parameters.

1. Physically connect the detector to the building network.
2. Configure the detector to use Ethernet.
 - Connect to the detector using USB following the procedure described in Section 5.2.1.
 - In the Ethernet tab for the detector:
 - For dynamic IP addresses, set **Automatically obtain IP Address** to on. Once it has been successfully allocated, record the IP Address for use in connection profiles. It can be found on the

detector status screen.

- For static IP addresses, set **Automatically obtain IP Address** to off and set the **IP Address**, **Subnet Mask** and **Default Gateway** to a valid address in the building network.
- Set the detector authentication password. Refer to Section 5.3.1 on page 56 for further information.

Connect to a detector using Xtralis VSC

1. Using the normal building network connection process, connect the PC to the network.
2. Add an Ethernet / WiFi connection using Connection Manager in Xtralis VSC. Refer to Section 5.1.2 for further information.
3. Enter the IP address of the detector previously set when enabling Ethernet connections. Where the IP address is not known, it may be viewed on the detector status screen using a USB connection.
4. Enter the Authentication Password previously set when enabling Ethernet connections.
5. Select **Connection > Connect and View**.
6. If the previously defined connection profile is set as the default connection, select OK, otherwise select Details, then select the required Ethernet connection from the list of available connection profiles and select OK.

5.2.3 Connecting to a detector via WiFi

Connection using WiFi between the detector and the PC installed with Xtralis VSC can be made using a router or access point (Figure 5-10). The example below shows both devices joined to the same wireless network. Complex networks are beyond the scope of this document.

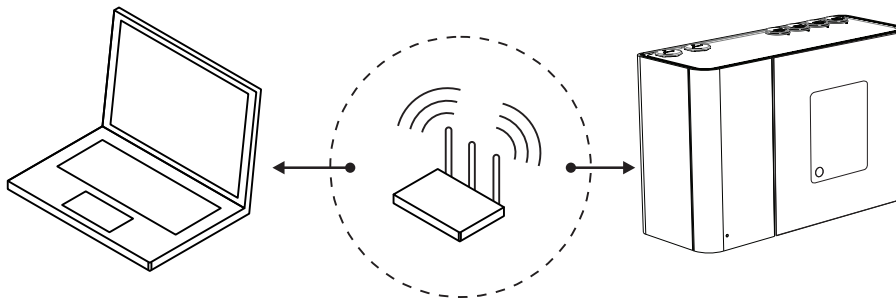

Figure 5-10: Connecting to a detector via WiFi using a router

Enabling WiFi Connection

The WiFi connection method only needs be configured once, and then edited if there is a change to any of the relevant building network connection parameters.

1. Connect to the detector using USB following the procedure described in Section 5.2.1.
2. In the WiFi tab for the detector:
 - For dynamic IP addresses, set **Automatically obtain IP Address** to on. Once it has been successfully allocated, record the IP Address for use in connection profiles. It can be found on the detector status screen.
 - For static IP addresses, set **Automatically obtain IP Address** to off, and set the the **IP Address**, **Subnet Mask** and **Default Gateway** to a valid address in the building network.
 - Set the SSID, security mode and WEP key or WPA pass phrase as required to connect to the building access point. Refer to Section 5.5.4 for further information.
 - Set the detector authentication password, using the Set Password button located in the General tab. Refer to Section 5.3.1 on page 56 for further information.

Connect to a detector using Xtralis VSC

1. Using the normal building network connection process, configure the PC to connect to the WiFi access point.
2. Add an Ethernet / WiFi connection profile using Connection Manager in Xtralis VSC. Refer to Section 5.1.2 for further information.
3. Enter the IP address of the detector previously set when enabling WiFi connections. Where the IP address is not known, it may be viewed on the detector status screen using a USB connection.
4. Enter the Authentication Password previously set when enabling WiFi connections.

5. Select **Connection > Connect and View**.
6. If the previously defined connection profile is set as the default connection, select OK, otherwise select Details, then select the required WiFi connection from the list of available connection profiles and select OK.

5.2.4 Connection to a detector via VESDAnet

A VEP-A10-P that is part of a VESDAnet network can be accessed via another VESDA-E device acting as a gateway:

- the VEP-A10-P must be physically connected to the VESDAnet, as described in Section 4.3.5.
- another VESDA-E detector can be used as a gateway to communicate between the PC with Xtralis VSC and any device connected to the VESDAnet.

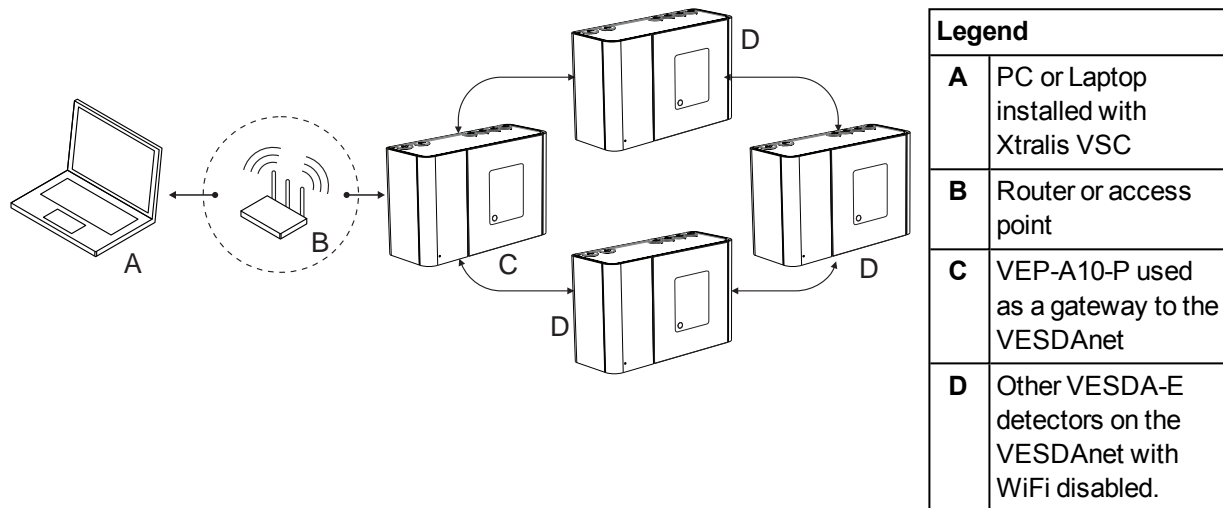

Figure 5-11: Connection to a detector via another detector on VESDAnet using a WiFi connection

Alternatively it is possible to connect using a High Level Interface (HLI) connected between the PC or Laptop with Xtralis VSC and the VESDAnet Socket in one of the devices on the VESDAnet.

Notes:

- The VEP-A10-P detector acts as a gateway on VESDAnet and allows a PC connected to the Ethernet, USB or WiFi connections to communicate with the gateway VEP-A10-P itself and any other device on VESDAnet.
- Refer to the VESDA Communications Guide for detailed information on VESDAnet.

Define a new Connection Profile (USB, Ethernet or WiFi connection between the PC and the detector which is acting as a gateway)

1. For VESDA-E detectors, follow the steps in Section 5.1.2 and add a USB, Ethernet or WiFi connection.

Access the VEP-A10-P

1. Connect to the gateway device in Xtralis VSC using Connection Manager. The software then automatically polls the VESDAnet for devices and lists them in the VESDAnet device list.

5.3 Security

The VEP-A10-P has two levels of protection against unauthorized access. For connection via Ethernet or WiFi, a password of at least 8 characters must be used. After connection, a four digit PIN is used to control the access level.

5.3.1 WiFi and Ethernet Authentication

A password is used to authenticate access over Ethernet or WiFi connection when using Xtralis VSC.

The password is set in the General options tab for the VEP-A10-P detector, and applies to both Ethernet and WiFi access. Refer to Section 5.5.3 on page 61 and Section 5.5.4 on page 63 for further information. When creating connection profiles in Xtralis VSC, the same password must be entered. Refer to Section 5.1.2 on page 49 for further information.

The password must conform to the following rules:

- 8 or more characters.
- Contains one or more numeric characters.
- Contains both upper case and lower case characters.

5.3.2 Access Control

When accessing the VEP-A10-P detector via Xtralis VSC, user functionality is initially limited. For additional privileges, the user must log in to the detector using an 4 digit numeric PIN code. In Xtralis VSC, select Logon from the Connection menu and enter the PIN.

Table 5-1: User Access Levels

User Level	Access Level	Functional Authorization
USR	Low	This is the USER or the OPERATOR level. The user can view the event log and change the date and time. They can also perform selected zone control functions.
ADM	High	At the ADMINISTRATOR level access is available to most functions. These include setting alarm thresholds, normalizing air flows, reset filter, and defining the relay configuration.
DST	Absolute	The DISTRIBUTOR level allows unlimited access to all the system commands and parameters.

The default PIN for each level of user is set at the factory. The distributor has access to the PINs for each level. PIN numbers are disclosed to authorized personnel attending accredited training courses.

After logging in the user has the option to change the default PIN. To guard against unauthorized access, if someone enters an incorrect PIN number three times they will not be allowed another attempt for ten minutes.

5.4 Commands

The following commands are able to be issued to the detector. As indicated below in Table 5-2, a small number of basic commands can be executed from the detector via buttons, while the full range of commands can be executed using the Xtralis VSC software.

Table 5-2: Detector Commands

Command	Description	Execute From	
		A button on the Detector	Xtralis VSC Software
Disable (Isolate)	The Disable command disables all the output relays associated with the detector. The aspirator remains active.	✓	✓
Enable	The Enable command enables all of the output relays associated with the detector.	✓	✓
Go to Standby	The Go to Standby sets the detector to Standby mode. See Section 7.1 on page 79 for a description of Standby mode.		✓
End Standby	The End Standby command is available when the detector is in Standby mode. The End Standby command causes the detector to exit Standby mode.		✓
Reset	The Reset command unlatches all latched alarms and faults, and returns relays to their normal state. Clears the Xtralis VSC active event list. Reset does not enable a disabled detector or reactivate a detector that is in Standby mode.	✓	✓
Start Normalize Air Flow	Starts the air flow normalization process for the selected detector. The normalization process determines the reference flow rate. The detector can be in normal or disabled mode, but not standby mode. The aspirator remains on throughout the normalization process and no fault is reported unless the process fails to successfully complete. The normalizing status may be observed on the "detailed status" tab in the Xtralis VSC software. To normalize the detector using the internal AutoConfig button, press and hold the button until the AutoConfig LED illuminates, then release the button. To cancel the normalization process, press and hold the button for 5 seconds. The LED will turn off.	✓	✓

Table 5-2: Detector Commands (continued...)

Command	Description	Execute From	
		A button on the Detector	Xtralis VSC Software
Start AutoLearn Flow	<p>In Xtralis VSC you will be prompted to set the period of time that the environment is monitored to allow the system to decide what flow thresholds are most appropriate.</p> <p>When the AutoLearn has finished, the flow thresholds are overwritten.</p> <p>After AutoLearn is complete, review to confirm that the thresholds are within ranges allowed by local codes and standards.</p> <p>Refer to Chapter 6 on page 77 for more information.</p> <p>To initiate AutoLearn Smoke and Flow using the internal AutoConfig button, press and hold the button until the AutoConfig LED starts flashing (approximately 15 seconds), then release the button.</p>		✓
Cancel AutoLearn Flow	<p>Cancels the AutoLearn Flow process.</p> <p>Flow thresholds will remain at levels set prior to commencing AutoLearn Flow.</p> <p>To cancel AutoLearn Smoke and Flow functions using the internal AutoConfig button, press and hold the button for 5 seconds. The LED will turn off.</p>		✓
Start AutoLearn Smoke	<p>In Xtralis VSC you will be prompted to set the period of time that the environment is monitored to allow the system to decide what smoke thresholds are most appropriate.</p> <p>When the AutoLearn has finished, the smoke thresholds are overwritten.</p> <p>After AutoLearn is complete, review to confirm that the thresholds are within ranges allowed by local codes and standards.</p> <p>Refer to Chapter 6 on page 77 for more information.</p> <p>To initiate AutoLearn Smoke and Flow using the internal AutoConfig button, press and hold the button until the AutoConfig LED starts flashing (approximately 15 seconds), then release the button.</p>		✓
Cancel AutoLearn Smoke	<p>Cancels the AutoLearn Smoke process.</p> <p>Smoke thresholds will remain at levels set prior to commencing AutoLearn Smoke.</p> <p>To cancel AutoLearn Smoke and Flow functions using the internal AutoConfig button, press and hold the button for 5 seconds. The LED will turn off.</p>		✓
Rebuild Zone List	<p>Re-learns the list of display modules that are assigned to the detector on the VESDAnet.</p>		✓
Start Major Fault Test	<p>Generates a major fault on the detector and de-energizes the fault relay for 2 minutes.</p>		✓

Table 5-2: Detector Commands (continued...)

Command	Description	Execute From	
		A button on the Detector	Xtralis VSC Software
Start Minor Fault Test	Generates a minor fault on the detector and de-energizes the fault relay for 2 minutes.		✓
Start Alarm Test	Simulates full scale smoke level which causes the Alert, Action , Fire 1 and Fire 2 alarm conditions to occur. Alarm relays will energize unless the detector is disabled.		✓
Start Air Flow Fault Test	Tests the air flow sensing system by shutting down the aspirator.		✓
Start Relay Test	Tests the available relays by activating and deactivating as required.		✓
Start LED Test	Tests each LED by cycling through all LEDs on the detector display panel.		✓
Return to Factory Defaults	Restores the configuration of the detector to the initial factory default values.		✓
Set System Date and Time	Sets the detector date and time.		✓

5.5 Configuration Options

The VESDA-E VEP-A10-P detector can be configured using the Xtralis VSC software.

The following sections describe the configuration options available in Xtralis VSC.

5.5.1 General Options

The General options include some basic identification information for the detector.

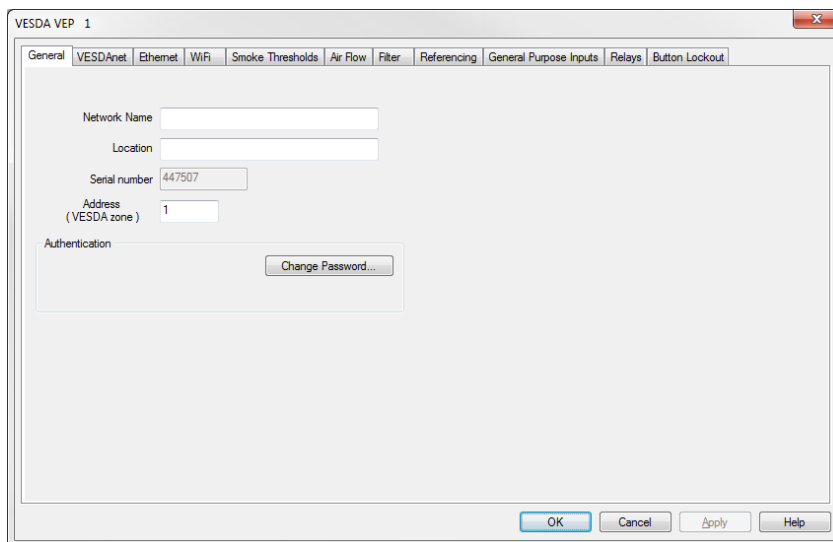

Figure 5-12: General Options

The General configuration options are as follows:

- **Network Name:** The name of the VESDAnet network. (The user can leave this blank if desired.)
- **Location:** A description of the physical location of the detector. This name will appear on Xtralis VSC and on the LCD display of the A10 model detector.
- **Serial Number:** The serial number of the device. This is factory set and cannot be changed.
- **VESDA Zone:** The unique zone number used to link this detector and remote display/relay devices or remote relay which output alarm and trouble status for this detector to the Fire Alarm Control Panel.

Authentication

- **Change Password:** The password used to authenticate Ethernet and WiFi access. Refer to Section 5.3.1 on page 56 for further information.

5.5.2 VESDAnet Options

The VESDAnet options provide the ability to control network data transmission behaviour for VESDAnet connections.

Note: Refer to Section 5.6 for the default settings.

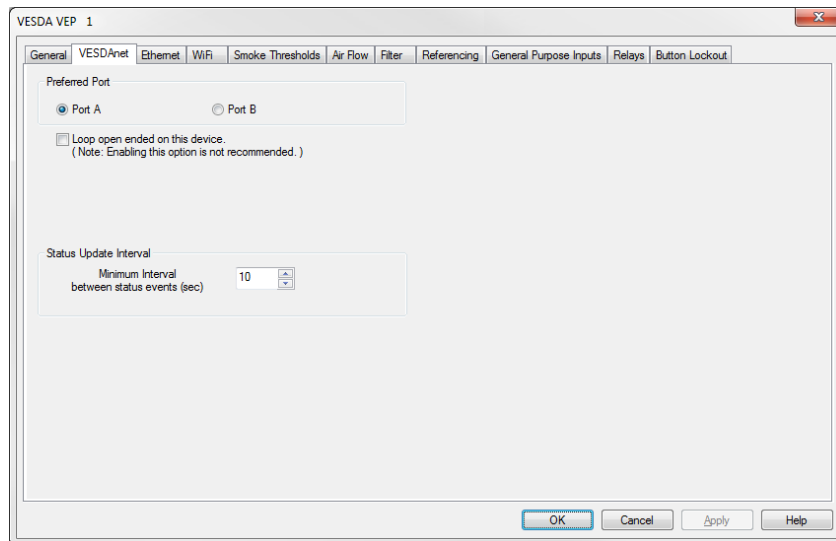

Figure 5-13: VESDAnet Communications Options

The Communications configuration options are as follows:

- **Preferred Port:** The preferred VESDAnet port to be used to transmit network data from this device. The non-preferred port is used if for some reason transmissions on the preferred port fail. For best performance in large networks, this setting should be randomly distributed between connected devices.
- **Loop Open Ended on This Device:** This should be checked if the network has been wired so either VESDAnet port A or VESDAnet B is not connected on this detector. (Xtralis recommends that VESDAnet ports A and B are always connected so this option should normally not be checked.)
- **Status Update Interval:** The minimum time interval between status updates for the selected detector.

5.5.3 Ethernet Options

The Ethernet options provide the ability to configure the detector to join an existing wired Ethernet network using the normal building network connection process or be directly connected to a PC or laptop.

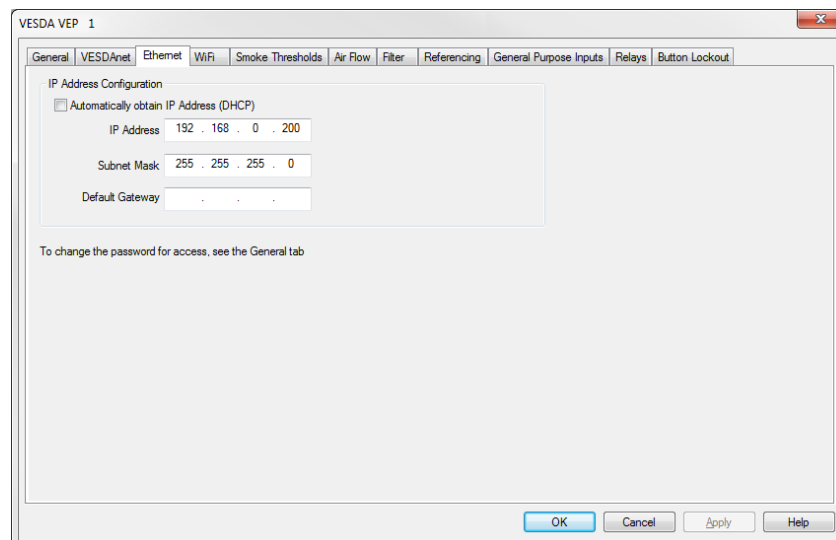

Figure 5-14: Ethernet Options

The Ethernet configuration options are as follows:

Dynamic IP Address Configuration

- **Automatically obtain IP Address:** Controls whether the VEP-A10-P uses a static IP address or automatically obtains an address from a DHCP server available on the building network. If this option is selected, the IP address, Subnet Mask and Default Gateway fields are disabled. Once the IP address has been successfully obtained by the detector, it is displayed on the detector detail status screen.

Static IP Address Configuration

- **IP Address:** IPV4 static address. This address must be used when creating a connection profile for the detector in Xtralis VSC.
 - The default IP address is 192.168.0.200. This allows direct connection between a PC or Laptop and the VEP-A10-P using a standard Ethernet lead.
 - Prior to connecting the detector to a router or other gateway device, the default address must be changed to an address in the range used by the router. This can be done by connecting to the detector using the USB port.
- **Subnet Mask:** The subnet mask for the network.
- **Default Gateway:** The IP address of the router or other gateway device that is servicing the network.

5.5.4 WiFi Options

The WiFi options provide the ability to configure the detector to join an existing WiFi network using the normal building network connection process.

After the WiFi parameters have been entered and the user selects Apply or OK, the detector will connect to the access point and remain connected while the access point is available. The WiFi LED inside the detector is continuously lit while the detector is connected to the access point, and is turned off if the detector is not connected to the access point.

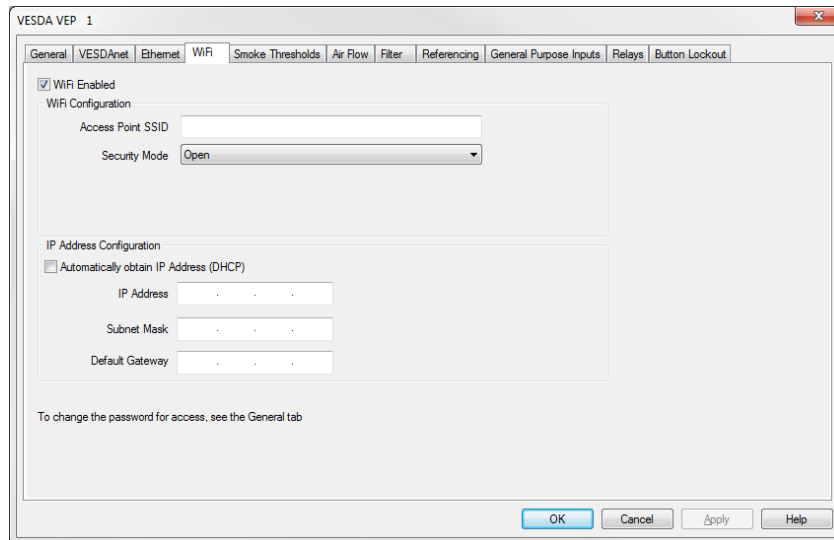

Figure 5-15: WiFi options

WiFi Network Connection Parameters

The following parameters are required to join the detector with an existing WiFi network:

- **WiFi Enabled:** Controls whether detector attempts to use WiFi and connect to an access point.
- **Access Point SSID:** Set by installer to suit building access point.
- **Security mode:** Set by installer to suit building access point
- **Key:** WPA or WEP Key required to join the VEP-A10-P to the building network. This field is disabled if the Security Mode is set to Open.

WiFi IP Configuration Parameters

The following parameters allow setting of a dynamic or static IP address for the VEP-A10-P on the WiFi network:

Dynamic IP Address Configuration

- **Automatically obtain IP Address:** Controls whether the VEP-A10-P uses a static IP address or automatically obtains an address from a DHCP server. If this option is selected, the IP address, Subnet Mask and Default Gateway fields are disabled. When the detector is joined to the network, the IP address that has been allocated to the detector by the DHCP server can be viewed on the detector status screen in Xtralis VSC by using a USB connection.

Static IP Address Configuration

- **IP Address:** IPV4 static address
- **Subnet Mask:** Subnet mask for static address
- **Default Gateway:** Gateway for static address

5.5.5 Smoke Threshold Options

The Smoke Threshold options provide the mechanism to set the smoke obscuration trigger point for each alarm level, and the ability to assign day or night thresholds to cater for different levels of activity in the protected area during these times.

Refer to Section 5.6 for the default settings.

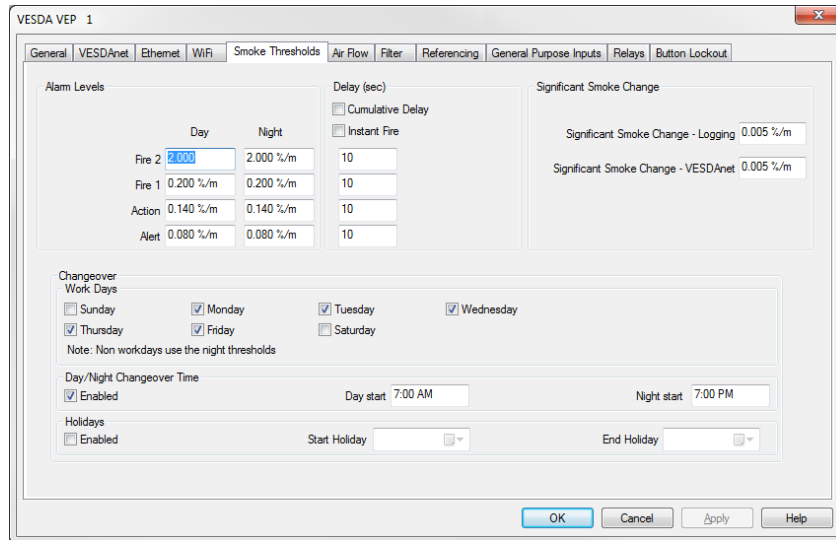

Figure 5-16: Smoke Threshold Options

The Smoke Threshold configuration options are as follows:

- **Day Thresholds:** The settings for day time smoke thresholds. The threshold and the delay are used together to decide when to trigger the alarm condition.
- **Night Thresholds:** The settings for night time smoke thresholds. The threshold and the delay are used together to decide when to trigger the alarm condition.
- **Delay:** The length of time between the alarm threshold being reached and the relay operation
 - **Cumulative Delay:** If checked the delay timer for each alarm condition will not start until both the smoke level has exceeded the threshold and the delay timer for the previous alarm condition has expired. If not checked the delay timer for each alarm condition will start immediately when the smoke level exceeds the threshold.
 - **Instant Fire:** If checked, the Fire 1 time delay is ignored when the smoke exceeds the Fire 1 threshold before the Alert and Action conditions have occurred.
- **Significant Smoke Change - Logging:** The smoke change level at which an event is recorded in the Event Log.
- **Significant Smoke Change - VESDAnet:** The smoke change level at which a smoke status update is output on VESDAnet.
- **Changeover:**
 - **Work Days:** Select which days use both day and night thresholds. Night time thresholds are used if a day is not selected.
 - **Day / Night Changeover Time:** The settings for the timing of the threshold changeover.
 - **Holidays:** The settings used to define a holiday period. Use the dropdown calendars to choose the start and end times of the holiday (or break) period. Night time thresholds are used during the holiday period.

5.5.6 Airflow Options

The Airflow options provide the ability to set:

- limits for what the detector considers to be normal airflow behavior for the sampling pipe network
- which pipe inlets are being used
- aspirator speed

These settings should be confirmed in the ASPIRE design of the sampling pipe network.

Note: Refer to Section 5.6 for the default settings.

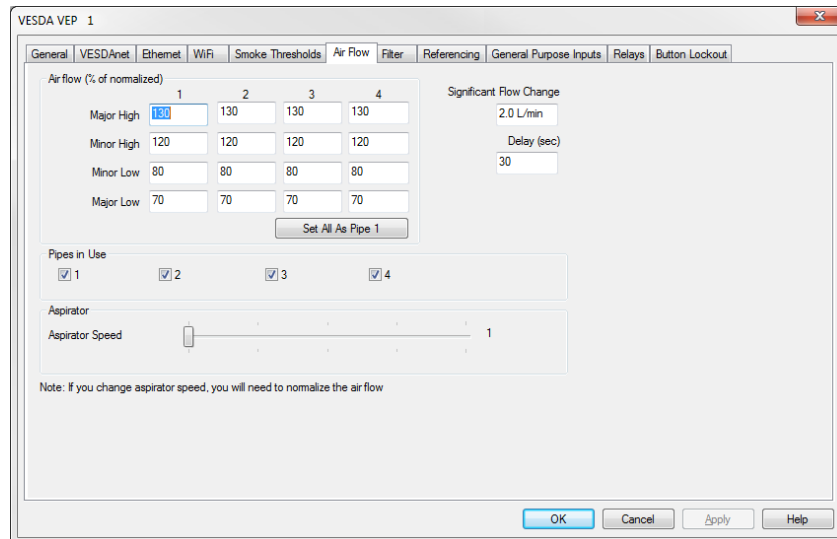

Figure 5-17: Airflow Options

The Airflow configuration options are as follows:

- **Air Flow:** The air flow conditions, as a percentage of the normalized air flow, that will cause a fault to be reported. If the installation site flow conditions vary significantly, it is recommended that the Major High and Major Low parameters are set closer to their limits.
 - **Major High:** The level of air flow considered to be so far above normal as to require urgent attention.
 - **Minor High:** The level of air flow considered to be above normal but not urgent.
 - **Minor Low:** The level of air flow considered to be below normal but not urgent.
 - **Major Low:** The level of air flow considered to be so far below normal as to require urgent attention.
- **Significant Flow Change:** The amount of airflow change at which an event is recorded in the event log.
- **Delay:** The length of time between the air flow fault threshold being reached and the fault relay operation.
- **Pipes in Use:** The pipes that are actually being used. Refer to Section 3.3 on page 17 for further information.
- **Aspirator:** Select the required Aspirator Speed setting 1 through 5, as determined using ASPIRE.

5.5.7 Filter Option

The Filter option page allows you to define the time period after which a filter fault will be generated.

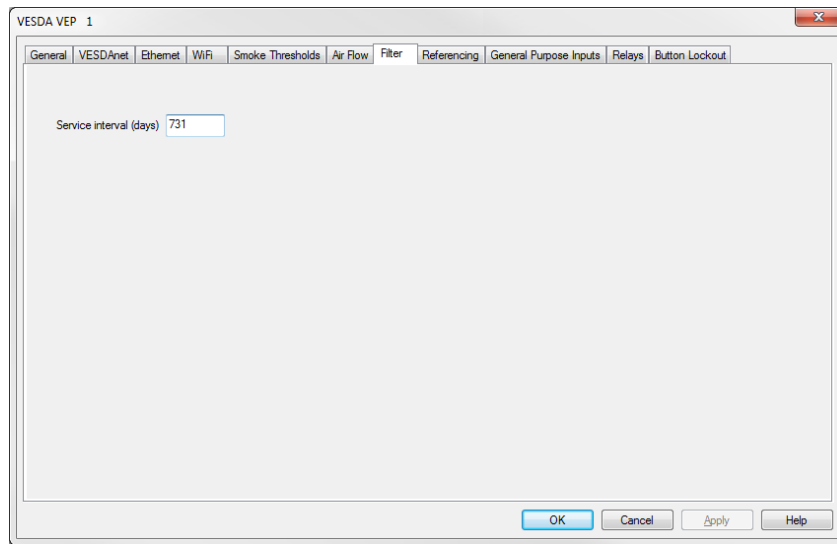

Figure 5-18: Filter Options

Service Interval (days): The time period after a new filter is installed at which non urgent fault "Filter smoke-dust limit nearly exceeded " (Fault 767) will be generated.

5.5.8 Referencing Options

Periodically, smoke and other pollutants from external sources may enter a protected zone temporarily raising the smoke level. In this case the detector will detect the background smoke and generate an alarm. Referencing is a system design technique employed to compensate for such rises in background smoke levels and therefore reduce nuisance alarms in high sensitivity areas.

A separate non-scanning VESDAnet-capable detector is used to draw air from the external source and produce a reference reading of the background level of smoke and pollutants. The reference reading is then subtracted from the smoke level of the VEP-A10-P detector monitoring the protected area. This allows the VEP-A10-P detector to determine if a rise in smoke levels is due to background pollution or a problem inside the protected area. The ability to compensate for the background level of smoke greatly reduces the chance of false alarms.

The smoke level from the reference detector which is subtracted from the smoke level of the VEP-A10-P detector monitoring the protected area is limited to 50% of the Fire 1 alarm threshold of the VEP-A10-P.

A single reference detector can be used by multiple VESDA detectors within the protected area.

The percentage of reference smoke level subtracted can be set differently for each detector monitoring the protected area. This is set using the dilution factor parameter.

There may be a time delay before the smoke moves from the external source to the protected area. This delay can be accounted for by delaying the measured reference smoke level before subtracting it from the VEP-A10-P detector smoke level. This is set using the delay parameter..

Note: Refer to Section 5.6 on page 73 for the default settings.

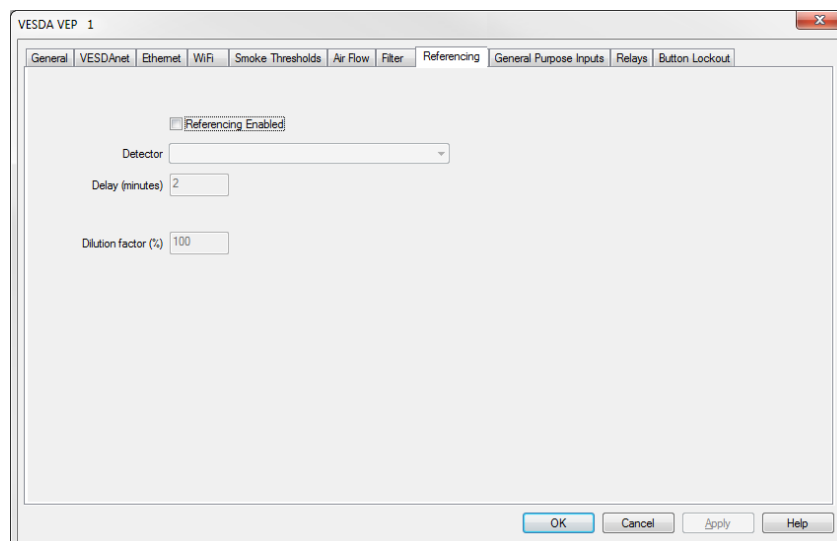

Figure 5-19: Referencing Options

The Referencing configuration options are as follows:

- **Referencing Enabled:** If checked, referencing is enabled.
- **Detector:** The name of the detector or system which provides the reference signal. Select from other non-scanning detectors on the VESDAnet.
- **Delay:** The length of time between the measurement of the external smoke level by the reference detector and the internal subtraction of this smoke level from the VEP-A10-P smoke level.
- **Dilution Factor:** The percentage of the reference signal to be subtracted from the VEP-A10-P.

5.5.9 General Purpose Inputs Options

The General Purpose Inputs options page provides the ability to control the behavior of the Unmonitored and Monitored General Purpose Inputs (GPIs).

The GPIs can be configured to initiate a number of different actions.

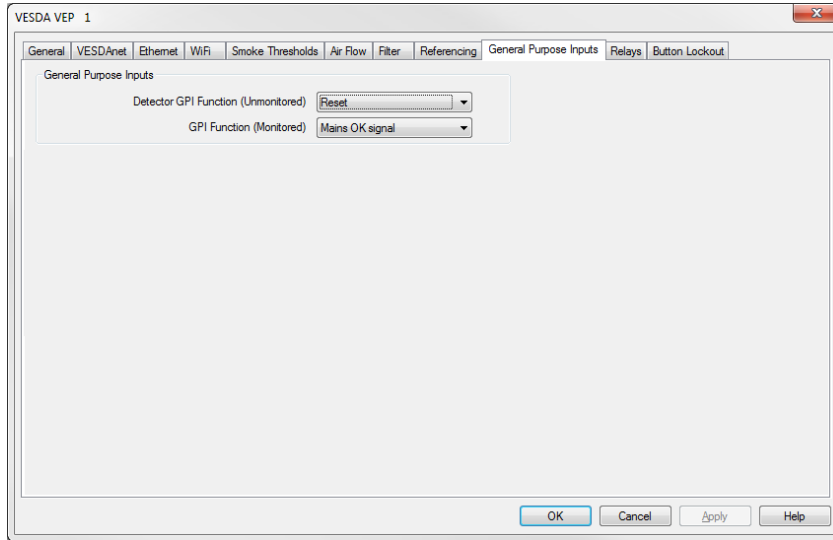

Figure 5-20: General Purpose Input Options

The configuration options are as follows:

- **GPI function (Unmonitored) and GPI function (Monitored):** Refer to Table 5-3 below for a description of the individual selections.

Table 5-3: GPI Operation

Function	State Change	
External Reset	Unmonitored GPI The detector resets on a 0 VDC to 5 VDC rising edge.	
	Monitored GPI The detector resets on a contact closure.	

Table 5-3: GPI Operation (continued...)

Function	State Change	
<p>Mains OK</p>	<p>Unmonitored GPI</p> <ul style="list-style-type: none"> The detector reports “Power Supply AC Input Failure” (fault 761) when ≤ 2 VDC. The detector does not report “Power Supply AC Input Failure” (fault 761) when ≥ 5 VDC. <p>Monitored GPI</p> <ul style="list-style-type: none"> The detector does not report “Power Supply AC Input Failure” (fault 761) while the contact is open. The detector reports “Power Supply AC Input Failure” (fault 761) while the contact is closed. <p>Refer to Figure 4-38 in Section 4.3.10 on page 42 and Section 4.3.11 on page 43 for further information.</p>	
<p>Standby Mode</p>	<p>Unmonitored GPI</p> <ul style="list-style-type: none"> The detector is held in Standby mode (see Section 7.1) while ≥ 5 VDC. The detector exits Standby mode at a 5 VDC to 0 VDC falling edge. <p>Monitored GPI</p> <ul style="list-style-type: none"> The detector is held Standby mode (see Section 7.1) while contact is closed. The detector exits Standby mode when the contact opens. <p>Note: No alarms can be generated while the detector is in standby mode.</p>	
<p>Disable</p>	<p>Unmonitored GPI</p> <ul style="list-style-type: none"> The detector is held disabled while ≥ 5 VDC. The detector is enabled on a 5 VDC to 0 VDC falling edge. <p>Monitored GPI</p> <ul style="list-style-type: none"> The detector is held disabled while contact is closed. The detector is enabled when the contact opens. <p>Note: No alarms are signalled while the detector is disabled.</p>	

Table 5-3: GPI Operation (continued...)

Function	State Change	
<p>Use Night-time Threshold</p>	<p>Unmonitored GPI</p> <ul style="list-style-type: none"> The detector uses night-time thresholds while ≥ 5 VDC. <p>Monitored GPI</p> <ul style="list-style-type: none"> The detector uses night-time thresholds while the contact is closed. <p>Note: While the GPI is off (contact open, voltage $\leq 2V$), the day or night thresholds are determined according to the internal clock and the configuration of the detector (using Xtralis VSC).</p>	
<p>Reset + Disable</p>	<p>Unmonitored GPI</p> <ul style="list-style-type: none"> Detector resets on a 0 VDC to 5 VDC rising edge and on 5 VDC to 0 VDC falling edge, and; <ul style="list-style-type: none"> Detector is held disabled while ≥ 5 VDC. Detector is enabled on a 5 VDC to 0 VDC falling edge. <p>Monitored GPI</p> <ul style="list-style-type: none"> The detector resets on closure or opening of the contact, and; <ul style="list-style-type: none"> The detector is held disabled while contact is closed. The detector is enabled when the contact opens. 	
<p>Inverted Reset</p>	<p>Unmonitored GPI</p> <ul style="list-style-type: none"> The detector resets on a 5 VDC to 0 VDC falling edge. <p>Monitored GPI</p> <ul style="list-style-type: none"> The detector resets on the opening of the contact. 	

Notes:

- When using the standby or disable options it is recommended that all remote displays on VESDAnet are configured to have the Isolate button locked out.
- When the detector is disabled or set to standby via the GPI, the status cannot be changed through the normal enable / disable function on the front panel or via Xtralis VSC or a remote display. Refer to Section 2.3.2 on page 6 for further information.
- When the night-time thresholds are invoked via the GPI, the clock settings for day-start and night-start are overridden.

5.5.10 Relay Options

The Relay options page provides the ability to determine which alarm or fault condition is assigned to each relay and whether each condition is latched. In addition, each relay can be configured Normally Energized or Normally De-Energized.

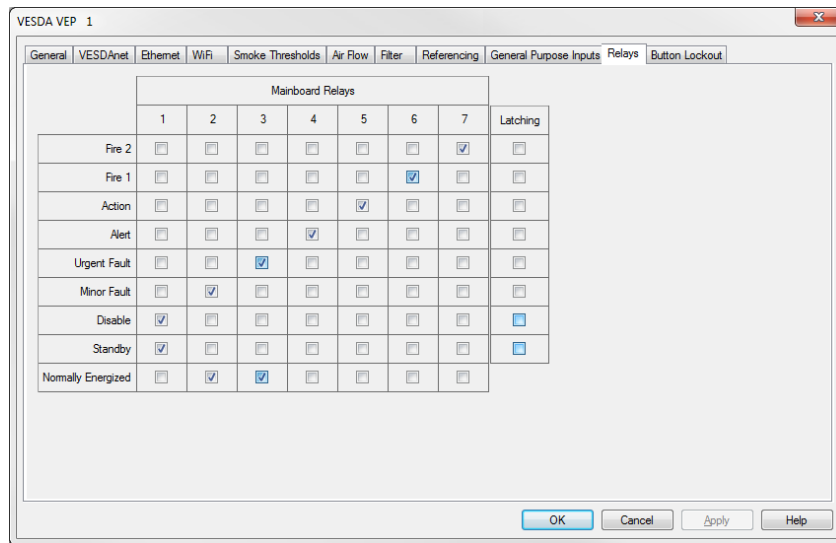

Figure 5-21: Relay Options

Relay Assignments: Select the conditions you want to assign to each relay by checking the checkbox(es) under the relay. The blue coloured checkboxes cannot be changed; e.g. Relay 6 will always respond to the Fire 1 condition. You can assign more than one condition to a relay.

Normally Energized: The Normally Energized or Normally De-Energized setting of each relay can be configured using the checkbox in the Normally Energized row:

- If checked the relay is set Normally Energized.
- If unchecked the relay is set Normally De-energized.

In the Normally De-energized mode no drive is applied to the relay coil until the assigned condition such as Alert or Fire 1 occurs. The Normally Energized mode is the opposite. Drive is removed from the relay coil when the condition occurs.

The default mode of the relays is listed in Table 4-2.

Latching: If the cause of a condition is removed (for example, smoke decreases below the threshold) and latching is enabled, the detector “remembers” the condition and holds the corresponding relays and displays in the active state as though the cause of the condition were still active.

Latching can be enabled for any alarm condition or for urgent or minor fault by checking the corresponding latching checkbox to the right of the condition.

5.5.11 Button Lockout Options

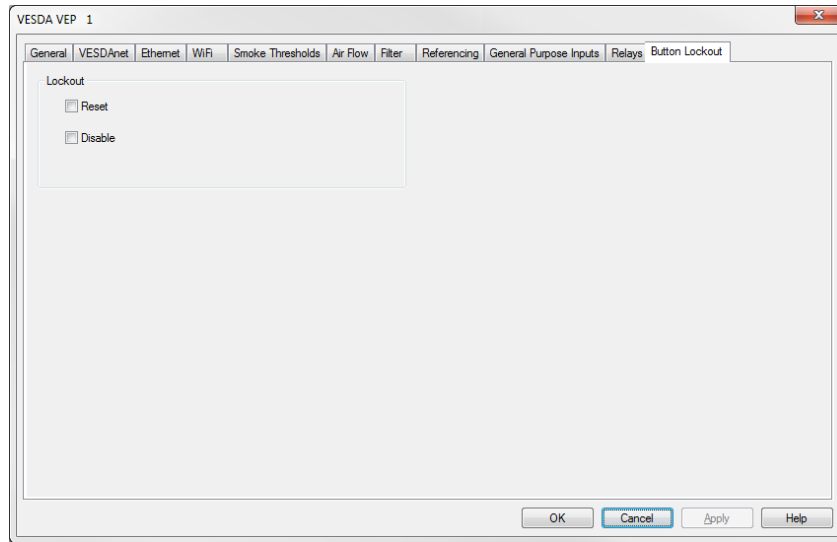

Figure 5-22: Button Lockout Options

Lockout:

The Reset and Disable functions cannot be executed using the detector front panel button if the corresponding checkbox is ticked."

5.6 Factory Default Settings

Table 5-4: Default Settings

Parameter	Default Values	Range		Affected by Return to Factory Defaults command
		Minimum	Maximum	
General				
Network name	Blank	n/a	n/a	Yes
Location	Blank	n/a	n/a	Yes
Address (VESDA zone) ¹	0	1	254	Yes
Detector Password ²	None	n/a	n/a	No
VESDAnet				
Preferred port	Port A	Port A	Port B	Yes
Loop open ended	Unchecked	Unchecked	Checked	Yes
Status Update Interval	10 seconds	2 seconds	10 seconds	Yes
Ethernet				
Automatically Obtain IP Address	Unchecked	Unchecked	Checked	No
IP Address ³	192.168.0.200	n/a	n/a	No
Subnet mask ³	255.255.255.0	n/a	n/a	No
Default Gateway	Blank	n/a	n/a	No
WiFi				
WiFi Enabled	Unchecked	Unchecked	Checked	No
WiFi Configuration				No
• Access Point SSID	Blank	n/a	n/a	No
• Security Mode	Open	n/a	n/a	No
• Security Key ⁴	None	n/a	n/a	No
IP Address Configuration				
• Automatically Obtain IP Address	Unchecked	Unchecked	Checked	No
• IP Address ³	192.168.1.100	n/a	n/a	No
• Subnet mask ³	255.255.255.0	n/a	n/a	No
• Default Gateway	Blank	n/a	n/a	No
Smoke Thresholds				
Alert	0.08 % obs/m (0.025 % obs/ft)	0.005 % obs/m (0.0016 % obs/ft)	2.0 % obs/m (0.625 % obs/ft)	Yes
Action	0.14 % obs/m (0.044 % obs/ft)	0.005 % obs/m (0.0016 % obs/ft)	2.0 % obs/m (0.625 % obs/ft)	Yes
Fire 1	0.20 % obs/m (0.0063 % obs/ft)	0.010 % obs/m (0.0031 % obs/ft)	2.0 % obs/m (0.625 % obs/ft)	Yes
Fire 2	2.0 % obs/m (0.625 % obs/ft)	0.02 % obs/m (0.0063 % obs/ft)	20.0 % obs/m (6.25 % obs/ft)	Yes

Table 5-4: Default Settings (continued...)

Parameter	Default Values	Range		Affected by Return to Factory Defaults command
		Minimum	Maximum	
Delays	10 seconds	0 seconds	60 seconds	Yes
Cumulative Delay	Unchecked	Unchecked	Checked	Yes
Instant Fire	Unchecked	Unchecked	Checked	Yes
Significant Smoke Change – Logging	0.005 % obs/m (0.0016 % obs/ft)	0.0001 % obs/m (0.000031 % obs/ft)	0.2 % obs/m (0.0063 % ofs/ft)	Yes
Significant Smoke Change - VESDAnet	0.005 % obs/m (0.0016 % obs/ft)	0.0001 % obs/m (0.000031 % obs/ft)	0.2 % obs/m (0.0063 % ofs/ft)	Yes
Work Days	Monday through Friday	n/a	n/a	Yes
Day Night Changeover Time				
• Enabled	Unchecked	Unchecked	Checked	Yes
• Day Start	7 AM	n/a	n/a	Yes
• Night Start	7 PM	n/a	n/a	Yes
Holidays				
• Enabled	Unchecked	Unchecked	Checked	Yes
• Start Holiday Date	Blank	n/a	n/a	Yes
• End Holiday Date	Blank	n/a	n/a	Yes
Air Flow				
Air flow thresholds				
• Major High	130%	105%	200%	Yes
• Minor High	120%	105%	200%	Yes
• Minor Low	80%	25%	95%	Yes
• Major Low	70%	25%	95%	Yes
Delay	30 seconds	15 seconds	250 seconds	Yes
Significant Flow Change	2.0 L/min	0.5 L/min	5 L/min	Yes
Pipes in Use	All pipes in use	No pipes in use	All pipes in use	Yes
Aspirator Speed	Setting 1	Setting 1	Setting 5	Yes
Filter				
Service Interval	731 days	1 day	3655 days	Yes
Referencing				
Referencing Enabled	Unchecked	Unchecked	Checked	Yes
Detector	Blank	Zone 1	Zone 254	Yes
Delay	2 minutes	0 minutes	15 minutes	Yes
Dilution Factor	100%	1%	100%	Yes
General Purpose Inputs				
GPI Function (Unmonitored)	Reset	n/a	n/a	Yes

Table 5-4: Default Settings (continued...)

Parameter	Default Values	Range		Affected by Return to Factory Defaults command
		Minimum	Maximum	
GPI Function (Monitored)	Mains OK	n/a	n/a	Yes
Relays				
Assignment of Relays to conditions	See Table 4-2	n/a	n/a	Yes
Normally Energized	See Table 4-2	n/a	n/a	Yes
Latching	Checked	Unchecked	Checked	Yes
Button Lockout				
Lockout				
• Reset	Unchecked	Unchecked	Checked	Yes
• Disable	Unchecked	Unchecked	Checked	Yes
AutoLearn Smoke and Flow Commands				
Duration	14 days	15 minutes	16 days	n/a

¹ The Xtralis VSC software forces the user to move the detector to a valid zone number.

² The user must set the password the first time. There is no default password.

³ Default value set in factory. Not modified by return to factory defaults command.

⁴ The WiFi Security Key type depends on the WiFi security method in use.

This page is intentionally left blank.

6 Commissioning

The VEP-A10-P has been designed to simplify commissioning processes. The AutoLearn function allows the unit to assess its environment and setup appropriate alarm and flow thresholds.

The detector is programmed using the Xtralis VSC software.

Once the VEP-A10-P detector has been commissioned, it will report alarms and faults according to the parameters defined during installation.

Note: Detectors should be commissioned with a smoke test.

Prior to commissioning the detector:

1. Check that the pipe network is clean and correctly fitted with all joints correctly seated and sealed (except the endcaps and the pipe which enters the detector which must not be glued). Ensure that the relevant pipes are selected as in use in Xtralis VSC.
2. Check that the power is connected and on. Ensure that the pipe flow rates comply with the minimum requirements listed in Section 3.1. Ignore any faults during this time.
3. Set the Pipes in Use value in the Airflow configuration options.
4. Set the aspirator setting to the value used when designing the system in ASPIRE to achieve the required transport time.
5. Normalize the airflow. This takes approximately 3 minutes, after which the pipe flow rates (%) should be close to 100%.
6. Reset the detector after normalization. It should now be running without faults, providing the flow rates are maintained as indicated in Section 3.1.

It is important that the protected environment is working under normal operating conditions when operating the AutoLearn processes.

Xtralis recommends that a 14 day period is used.

After AutoLearn is complete, review to confirm that the thresholds are within the range allowed by local codes and standards.

For code-specific information, see Codes and Standards Information for Air Sampling Smoke Detection on page iii.

6.1 AutoLearn Smoke

AutoLearn Smoke is initiated by using Xtralis VSC or the AutoConfig button located on the main board of the detector.

During the AutoLearn Smoke process, the detector determines the average smoke and peak smoke obscuration levels and sets suitable alarm thresholds for the operating environment. This process will minimize nuisance alarms due to normal environmental background variations.

During the learning cycle, if an alarm condition occurs, AutoLearn will not complete its cycle. In this situation the user must restart the AutoLearn process. If AutoLearn is halted, the alarm thresholds will be left at the previous settings.

Conditions experienced during learning are assumed to be representative of normal operating conditions.

The AutoLearn Smoke learning times can be set between 15 minutes and 16 days, with the default being set to 14 days.

If AutoLearn is running during the changeover period from Day to Night Thresholds, make sure that AutoLearn runs for at least an hour in both the Day and Night periods.

Table 6-1: AutoLearn Smoke range

Alarm Level	AutoLearn Smoke Range
Alert	0.005% – 2.0% obs/m (0.0016% - 0.625% obs/ft)
Action (Pre-Alarm)	0.005% – 2.0% obs/m (0.0016% - 0.625% obs/ft)
Fire1 (Alarm)	0.010 % – 2.0% obs/m (0.0031% - 0.625% obs/ft)
Fire2	0.020 % – 20.0% obs/m (0.0063% - 6.25% obs/ft)

For code-specific information, see Codes and Standards Information for Air Sampling Smoke Detection on page iii.

6.2 AutoLearn Flow

AutoLearn Flow process is initiated within Xtralis VSC or the AutoConfig button located on the main board of the detector.

During the AutoLearn Flow process, the detector normalizes the airflow and then monitors over time the average, maximum and minimum air flow levels and sets suitable air flow thresholds that will not give rise to nuisance flow faults due to normal flow variations.

During the learning cycle, if a flow fault is reached, AutoLearn will not complete its cycle. In this situation the user must restart the AutoLearn process. If AutoLearn is halted, the flow thresholds will be left at the previous settings.

Conditions experienced during learning are assumed to be representative of normal operating conditions.

The AutoLearn Flow learning times can be set between 15 minutes and 16 days, with the default being set to 14 days.

6.3 Commissioning Smoke Test

It is recommended that a smoke test be carried out to verify the integrity of the pipe network, to demonstrate that the system is working and to measure the transport time to the detector.

This test involves introducing a smoke sample at the furthest sampling hole and then measuring the time taken for the smoke to travel to the detector. Results are logged and compared to subsequent tests to note variations of the system.

Refer to the VESDA-E Commissioning Guide for details of the commissioning smoke test.

7 Maintenance

To maintain the VEP-A10-P detector at its peak performance level, the recommended maintenance schedule shown in Table 7-1 below should be followed.

Table 7-1: Recommended maintenance schedule for the VEP-A10-P detector

Maintenance Check	Quarterly	Six Monthly	Annual	Biennial
Power Supply and Battery	✓			
Check Pipe Network		✓		
Pipe Integrity Smoke Test			✓	
Check Pipe Flow			✓	
Clean Sampling Point			✓	
Flush Pipe Network			✓	
Replace Filter				✓

Notes:

- The above maintenance steps are preventative maintenance.
- Maintenance can be conducted by the original installer or an authorized distributor or service contractor.
- The required frequency of maintenance checks may vary depending upon local codes and standards and the environment of the installation.
- When smoke testing is done, follow the site procedures for preventing false alarms to monitoring services.



Caution: While the detector is disabled or put into Standby mode, no fire warnings will be annunciated by the detector. Prior to any maintenance or testing:

- Inform the appropriate supervising authority.
- Ensure that any ancillary devices dependent on the detector are isolated before work commences.



Attention : Pendant que le detecteur ou la zone est desactivee, aucun feu d'indication va etre emis par le detecteur. Avant tout entretien ou tester:

- Informer les autorité de supervision appropriée.
- S'assurer que tout les appareils auxiliaires dépendants sur le détecteur sont isolés avant de commencer aucun travail.

7.1 Standby

When maintenance is performed on the pipe network or sample points it is recommended that you temporarily set the detector to Standby in order to turn off the aspirator. Setting the VEP-A10-P to Standby mode deactivates the aspirator and stops all detection of alarms (but not detection and signaling of faults). Standby mode is signaled on relay #1 by default. Other relays may also be configured to signal standby mode. Refer to sections 4.3.6 and 5.5.10 for further information. For example, standby mode may be also signaled as an additional condition on the Fault Relay (Relay #3).

To set the detector to Standby mode using Xtralis VSC, select Go to Standby from the Device menu. The Disabled LED will blink and the aspirator will turn off.

To re-activate the unit, select End Standby from the Device menu.

7.2 Open the Door

Several maintenance functions require that front door be opened.

Open the Front Door

1. Release the door latch by inserting a thin screwdriver into the hole at the bottom left of the door and firmly pushing perpendicular to the door surface.
2. Pull the door open.

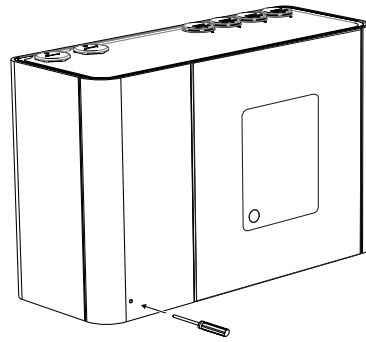

Figure 7-1: Open the door

7.3 Replacing the Filter

To maintain the operational integrity of the detector, it is recommended that the Filter be replaced every two years, or when a filter fault occurs. It may be necessary to replace the filter more often where the detector is installed in environments that experience high levels of contamination.

Remove the Filter

Note that it is not necessary to turn off the 24V DC power to the detector when removing and replacing the filter. The detector will turn off the aspirator when it detects that the filter has been removed and a fault will be signaled.

1. Open the front door. Ensure that the area around the filter is free of lint and dust before removing the filter. Refer to Section 7.2 on page 80 for further information.
2. Press on release mechanism in the direction arrowed (Figure 7-2).

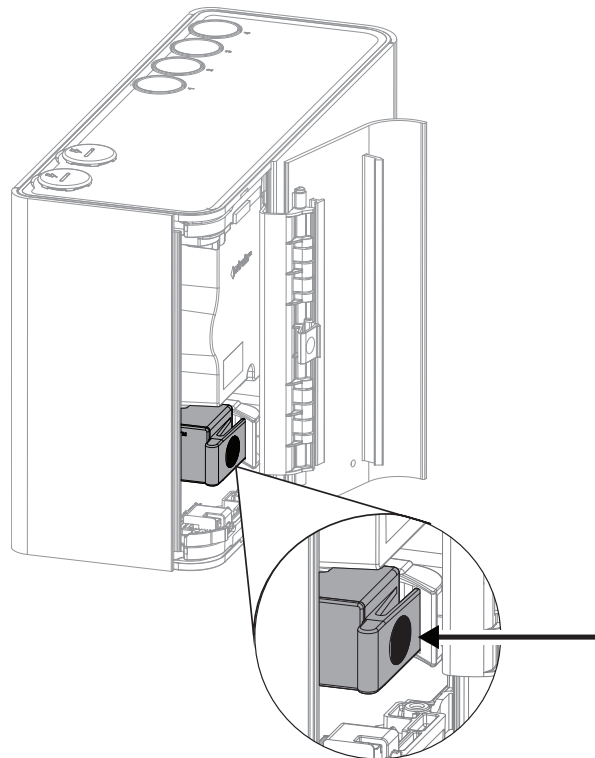

Figure 7-2: Release Filter

3. Tilt the filter towards the left-hand side of the detector (Figure 7-3). The filter has hinge pins at its base which allow it to be tilted on the chamber manifold.

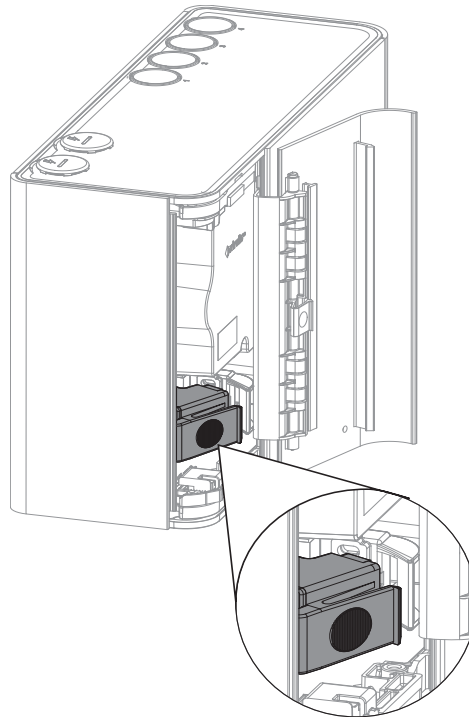

Figure 7-3: Tilt Filter towards the left-hand side of the detector

4. Lift the filter out of the detector case (Figure 7-4).

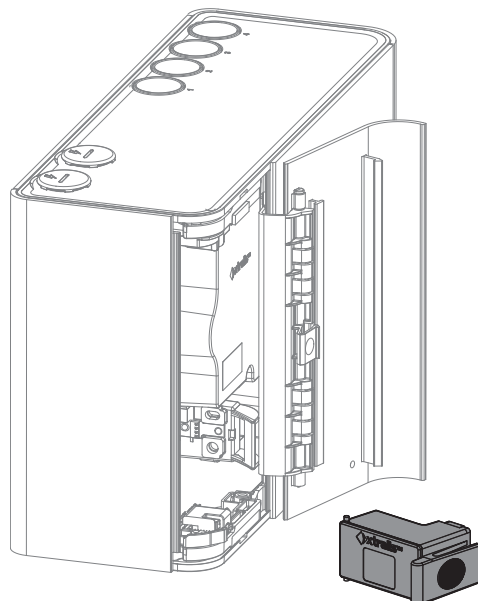

Figure 7-4: Remove Filter

Reinstall the Filter

Note: Ensure that the new filter is free of lint and dust.

1. Tilt the filter towards the left and position its hinge pins in their recess (Figure 7-5).

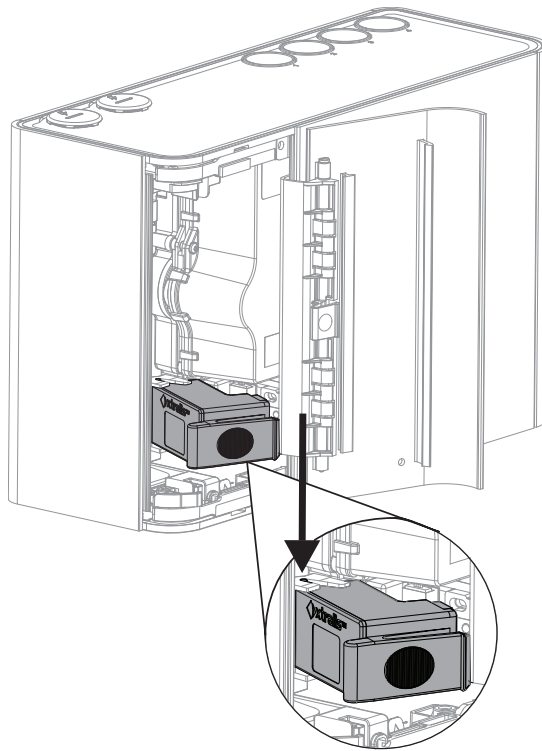

Figure 7-5: Engage hinge pins

3. Tilt the filter to the right.
4. Firmly press, as shown in Figure 7-6, until the filter makes a distinct clicking sound and no additional movement is possible.

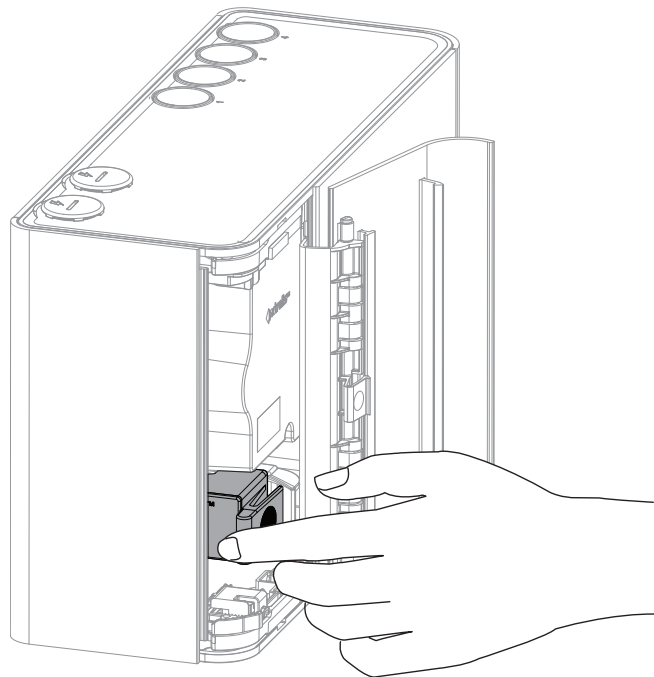

Figure 7-6: Reinstall the Filter

7.4 Remove the Fascia

Several maintenance functions require that the fascia be removed from the VEP-A10-P detector in order to perform them.



Caution: Electrostatic discharge (ESD) precautions need to be taken prior to removing the fascia from the detector. A wrist strap must be connected to the case of the detector (Figure 7-7).



Attention : Les precautions contre le decharge electrostatique dois etre respecter avant d'ouvrir le panneau du detecteur. Un bracelet doit être raccordé au panneau du détecteur (Figure 7-7).

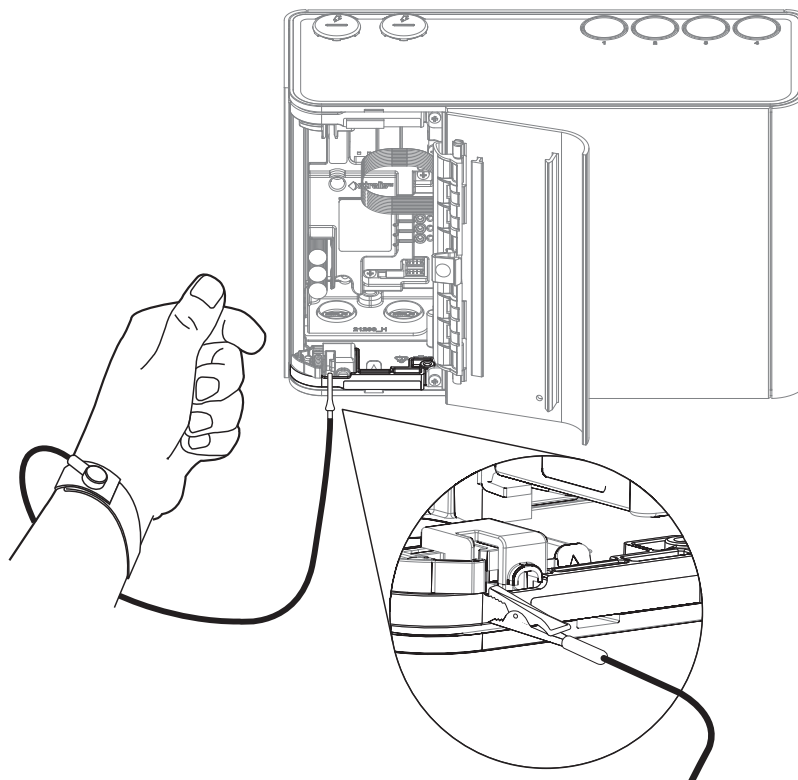

Figure 7-7: Wrist Strap application

Remove the Fascia

1. Turn off the 24V DC power to the detector.
2. Remove the two screws along side the door hinge, as shown below in Figure 7-8.

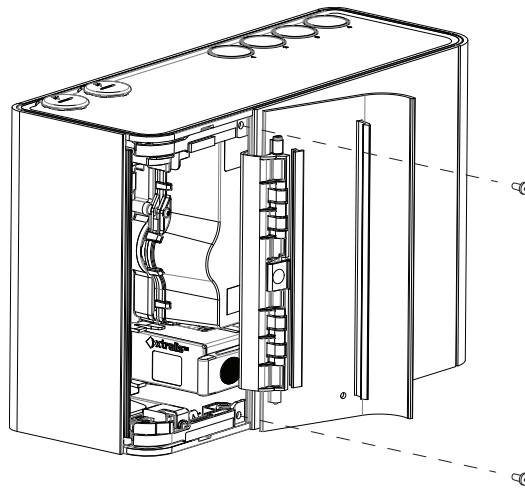

Figure 7-8: Fascia removal - remove screws

2. Remove the fascia and allow it to hang by the two tether straps.

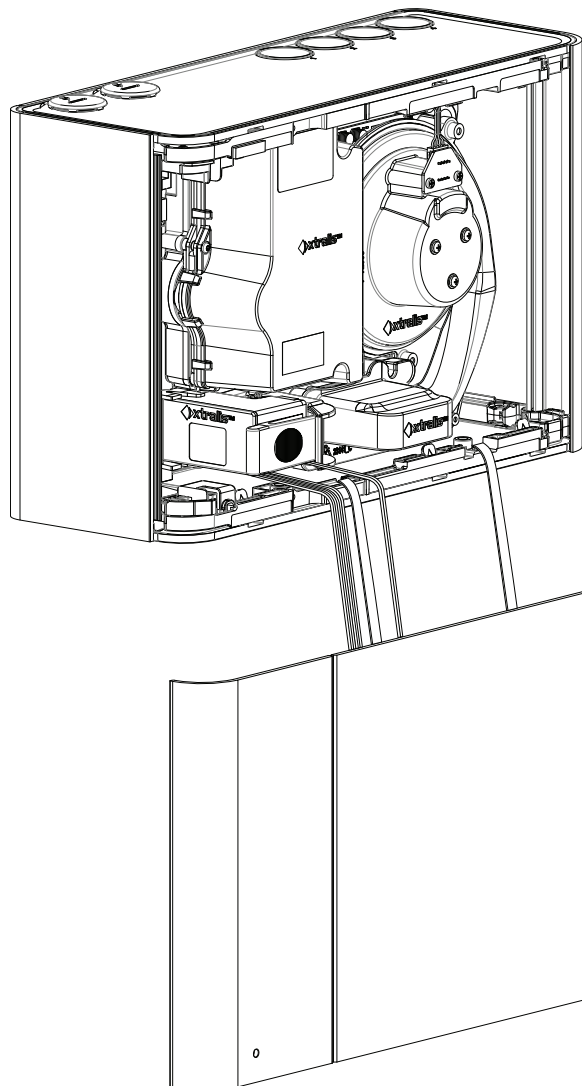

Figure 7-9: Fascia hanging on two tethers

7.5 Replacing the Aspirator



Caution: Electrostatic discharge (ESD) precautions need to be taken prior to removing the fascia from the detector. A wrist strap must be connected to the case of the detector (Figure 7-7).



Attention : Les precautions contre le decharge electrostatique dois etre respecter avant d'ouvrir le panneau du detecteur. Un bracelet doit être raccordé au panneau du détecteur (Figure 7-7).

Ensure the area surrounding the aspirator is clear of dirt and debris prior to replacement.

Care must be taken during aspirator replacement. The aspirator must be correctly seated; it is essential to ensure that the gaskets are not damaged or dislodged from the underside of the aspirator.

Remove the Aspirator

1. Turn off the 24V DC power to the detector.
2. Open the front door and remove the front fascia. Refer to Sections 7.2 and 7.4 for further information.
3. Disconnect the aspirator cable (A) (Figure 7-10).

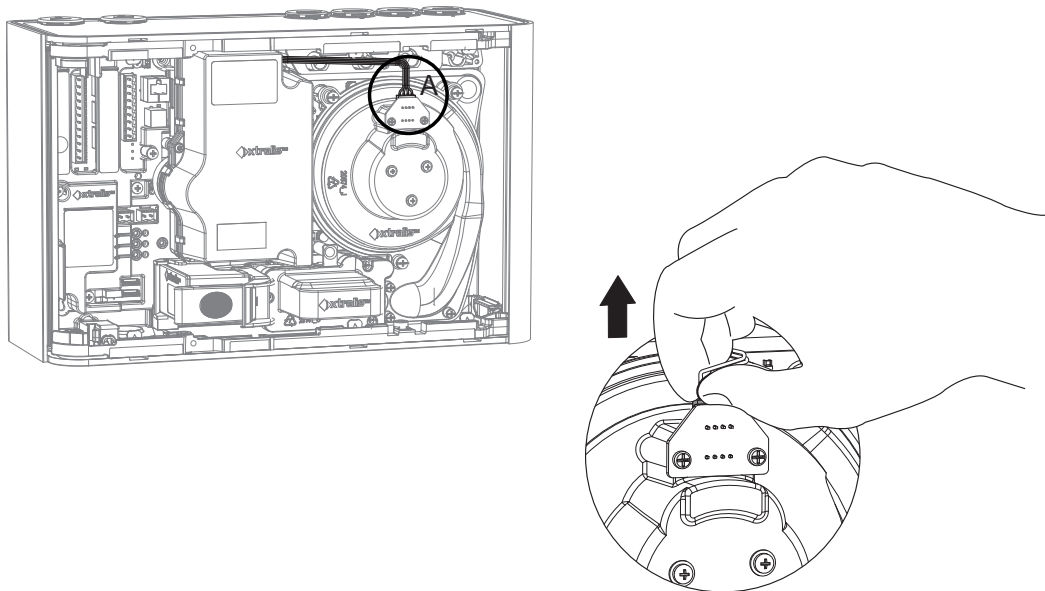

Figure 7-10: Disconnect the aspirator cable

4. Remove the six screws holding the aspirator to the detector base (Figure 7-11).

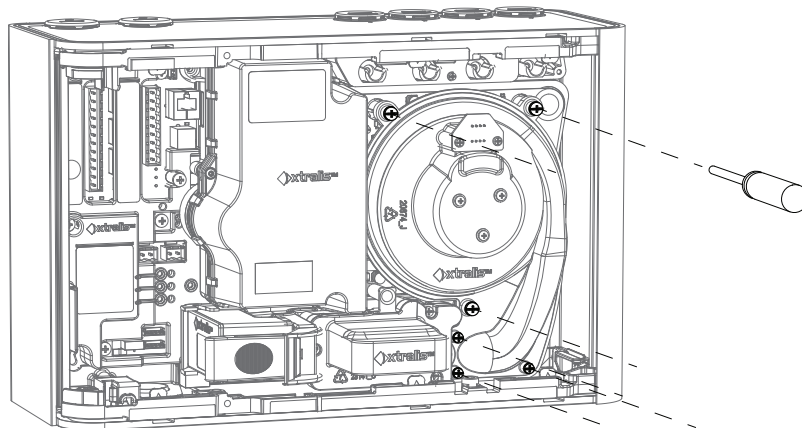

Figure 7-11: Remove aspirator mounting screws

5. Remove the aspirator perpendicular to the detector body (Figure 7-12).

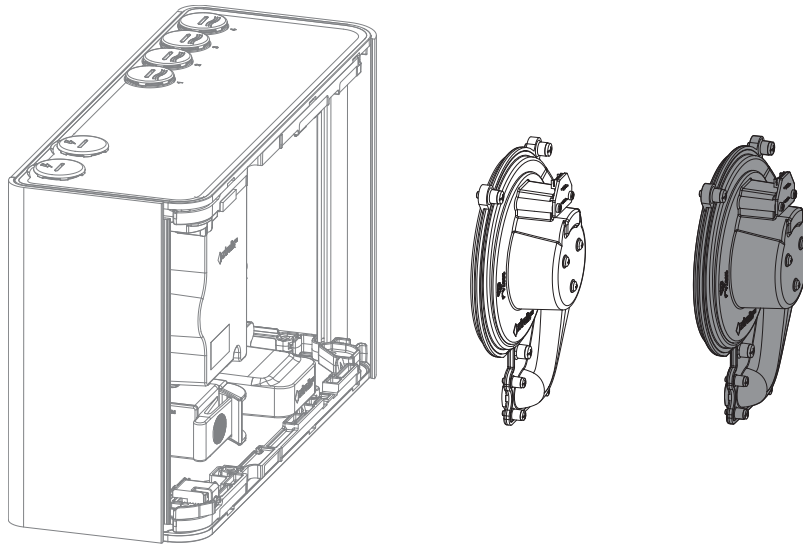

Figure 7-12: Remove aspirator from the detector

Reinstall the replacement Aspirator

To replace the aspirator, follow the removal procedure in reverse.

7.6 Replacing the Smoke Detection Chamber



Caution: Electrostatic discharge (ESD) precautions need to be taken prior to removing the fascia from the detector. A wrist strap must be connected to the case of the detector (Figure 7-7).



Attention : Les precautions contre le decharge electrostatique dois etre respecter avant d'ouvrir le panneau du detecteur. Un bracelet doit être raccordé au panneau du détecteur (Figure 7-7).

To replace the Smoke Detection Chamber, perform the following steps:

1. Open the front door and remove the front fascia. Refer to Sections 7.2 and 7.4 for further information.
2. Remove the Sampling Module as described in Section 7.7 on page 92.
3. Remove Smoke Detection Chamber as described below.
4. Install the new Smoke Detection Chamber as described below.
5. Reinstall the Sampling Module as described in Section 7.7 on page 92.

Remove the Smoke Detection Chamber

1. Turn off the 24V DC power to the detector.
2. Remove the Filter. Refer to Section 7.3 on page 81 for further information.
3. Remove the four screws holding the chamber to the detector base (Figure 7-13).

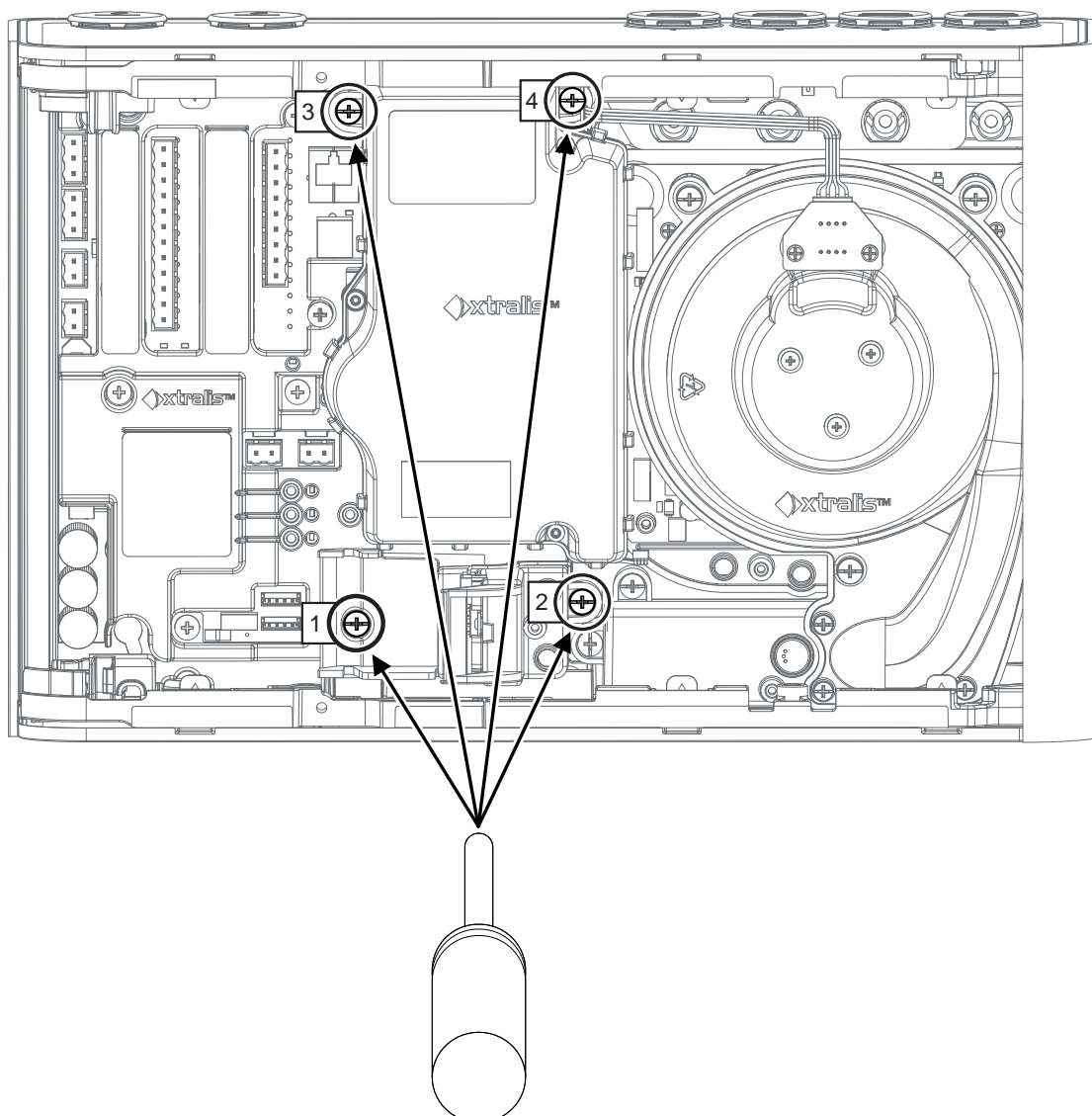

Figure 7-13: Undo Chamber retaining screws

4. Disconnect the chamber loom from the connector labeled J3 (Figure 7-14).

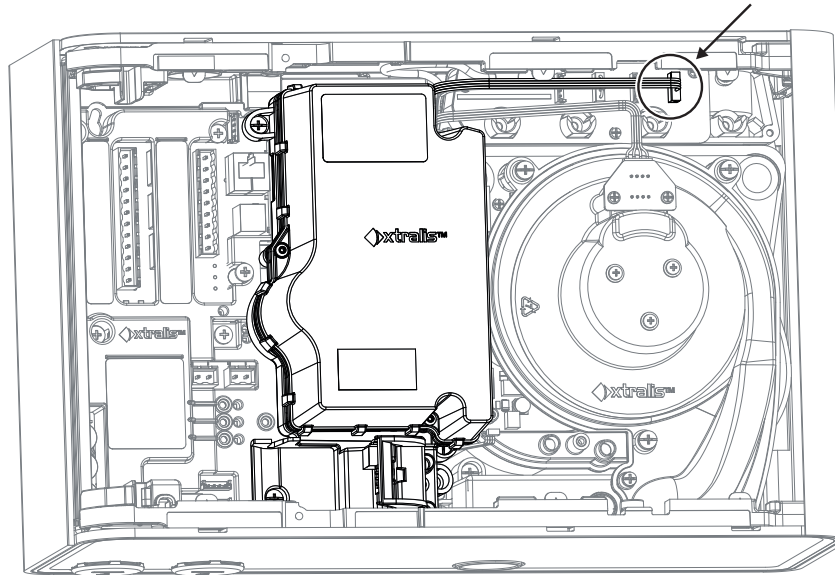

Figure 7-14: Disconnect Chamber Loom

5. Remove the chamber from the detector base (Figure 7-15).

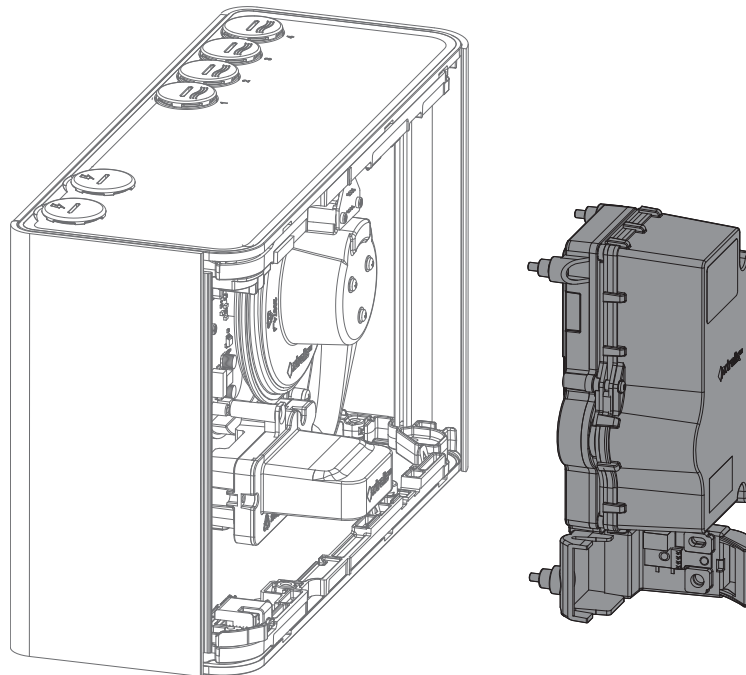

Figure 7-15: Remove the Chamber from the detector base

Installing the replacement Smoke Detector Chamber

1. Position the two indicated looms as shown in Figure 7-16. Position the indicated loom sections beside the air flow sensing module, not on top of it. This will ensure that, when installing the chamber, the looms are not caught between the chamber and the air flow sensing module.

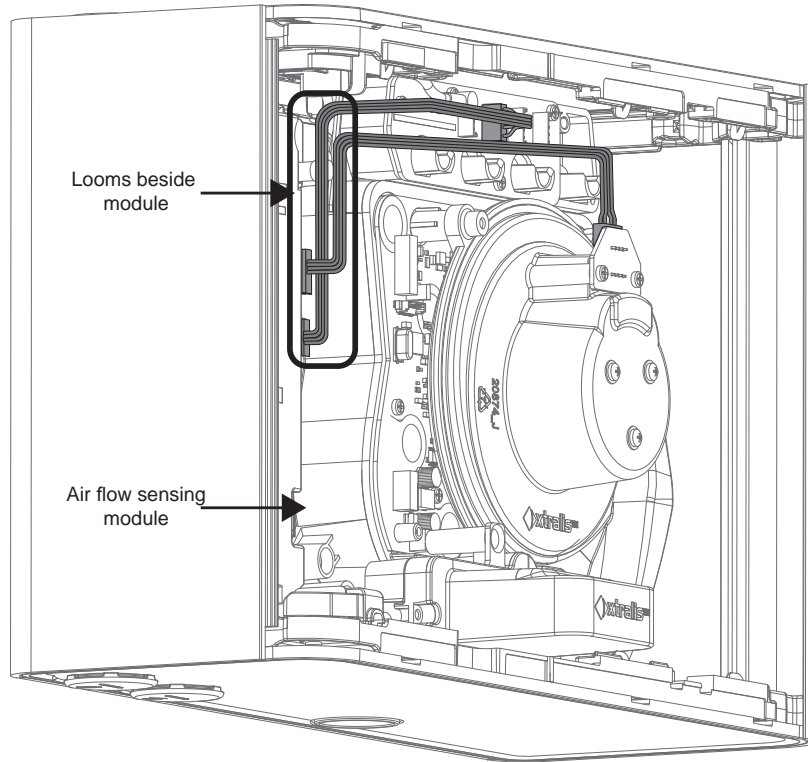

Figure 7-16: Position the gray loom

2. Position the chamber looms (A) and (B) as shown in Figure 7-17.

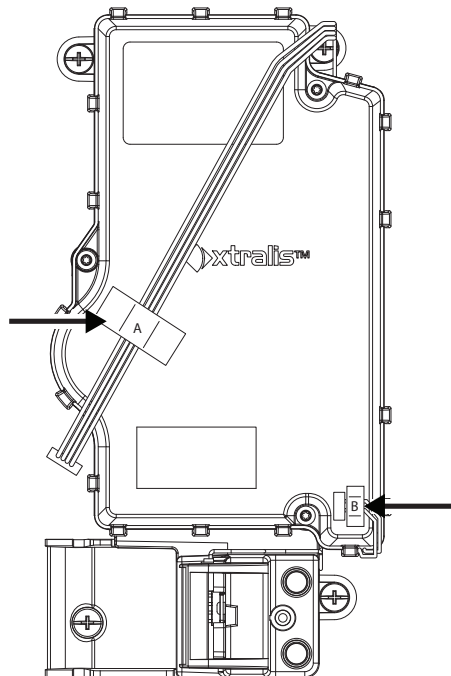

Figure 7-17: Position the Chamber looms

3. Re-install the chamber as shown in Figure 7-18. Be careful to hold looms (A) and (B) in the position shown so that the looms are not caught between the chamber and other parts of the detector.

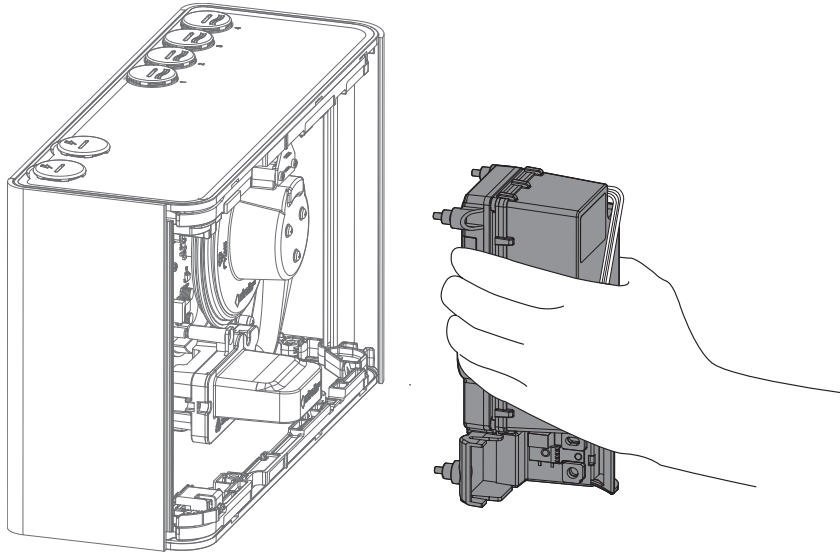

Figure 7-18: Install the Chamber

4. Secure the four screws which hold the chamber to the detector base (Figure 7-13).
5. Reconnect the loom to J3 (Figure 7-14).
6. Reinstall the Filter. Refer to Section 7.3 on page 81 for further information.

7.7 Replacing the Sampling Module



Caution: Electrostatic discharge (ESD) precautions need to be taken prior to removing the fascia from the detector. A wrist strap must be connected to the case of the detector (Figure 7-7).



Attention : Les precautions contre le decharge electrostatique dois etre respecter avant d'ouvrir le panneau du detecteur. Un bracelet doit être raccordé au panneau du détecteur (Figure 7-7).

Ensure the area around the Sampling Module is clear of dirt and debris prior to replacement.

Care must be taken during Sampling Module replacement. The Sampling Module must be correctly seated in order for a correct seal to be established between the Sampling Module and the rest of the detector. It is essential to ensure that the rubber seal on the underside of the Sampling Module is correctly in place.

Removing the Sampling Module

1. Turn off the 24V DC power to the detector.
2. Open the front door and remove the front fascia. Refer to Sections 7.2 and 7.4 for further information.
3. Disconnect the Sampling Module cable (Figure 7-19).

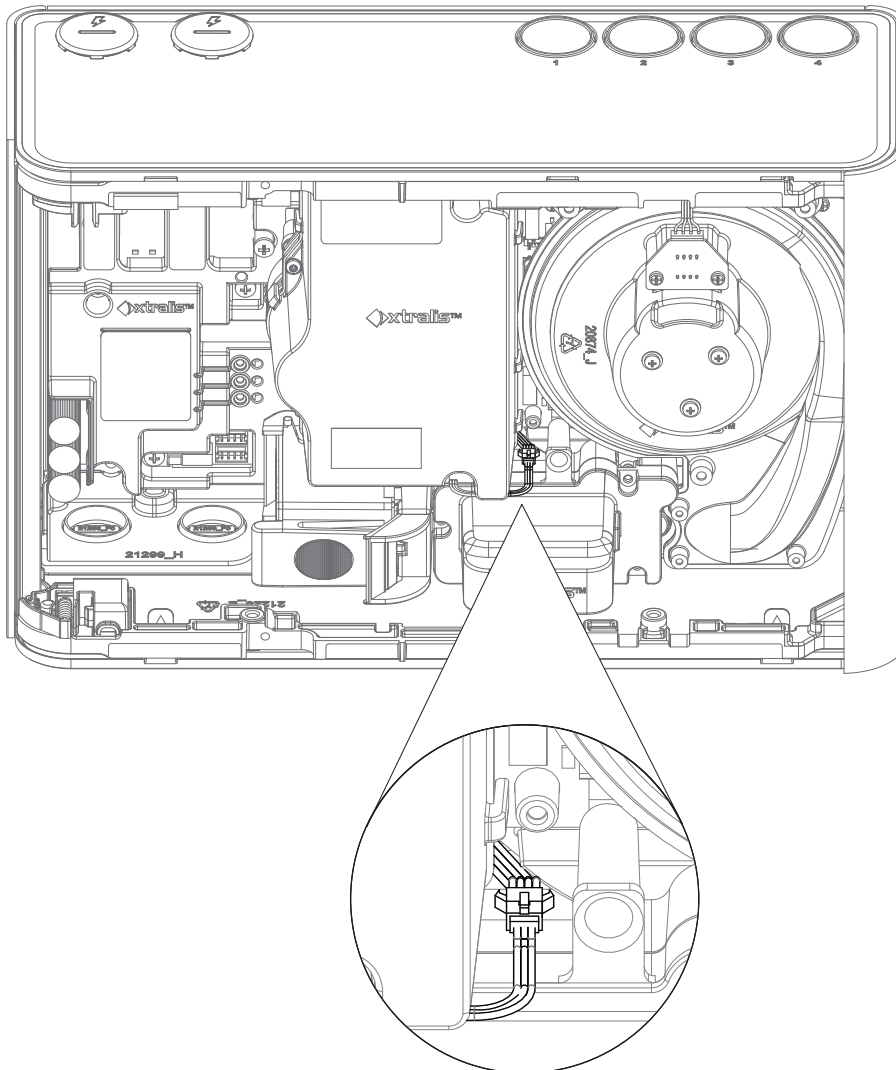

Figure 7-19: Disconnect the Sampling Module cable

4. Press on the lever on the connector to release the catch (Figure 7-20).

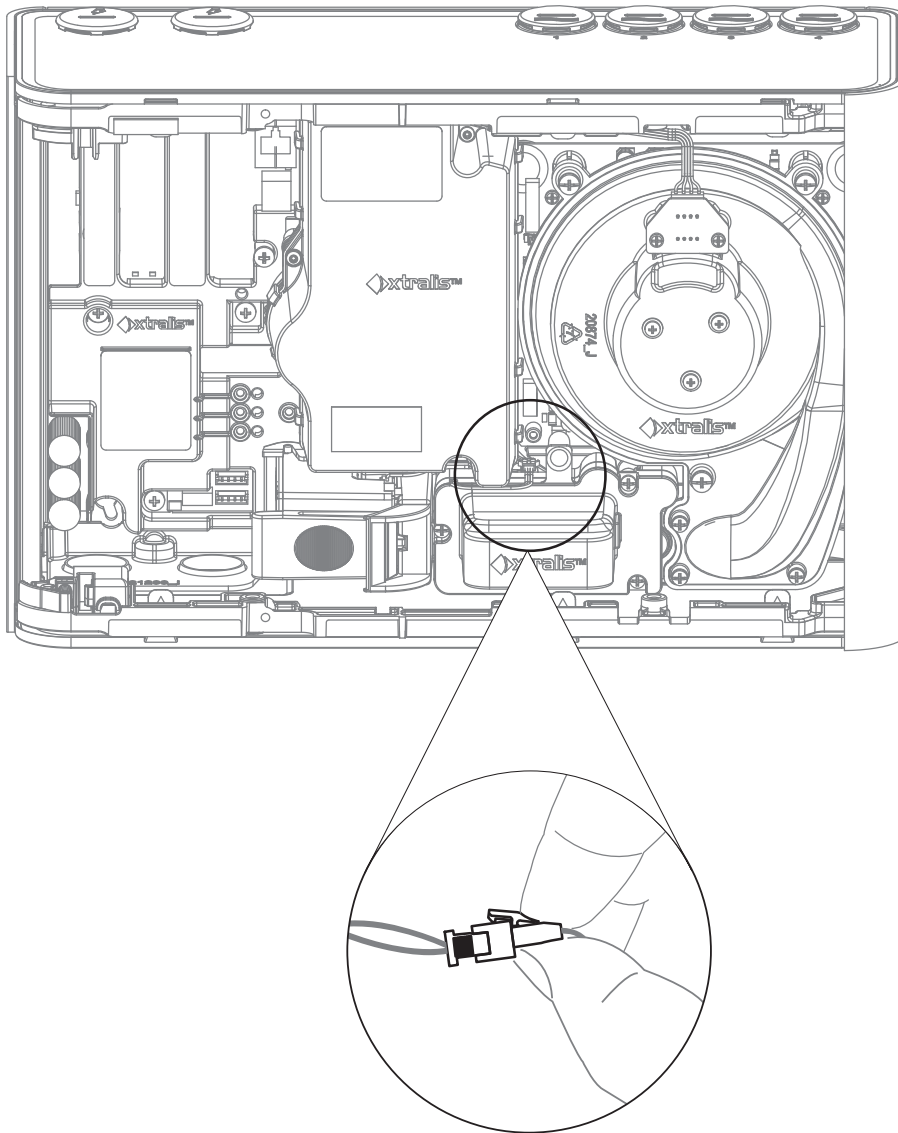

Figure 7-20: Release the Sampling Module cable

5. Undo the three screws holding the Sampling Module (Figure 7-21).

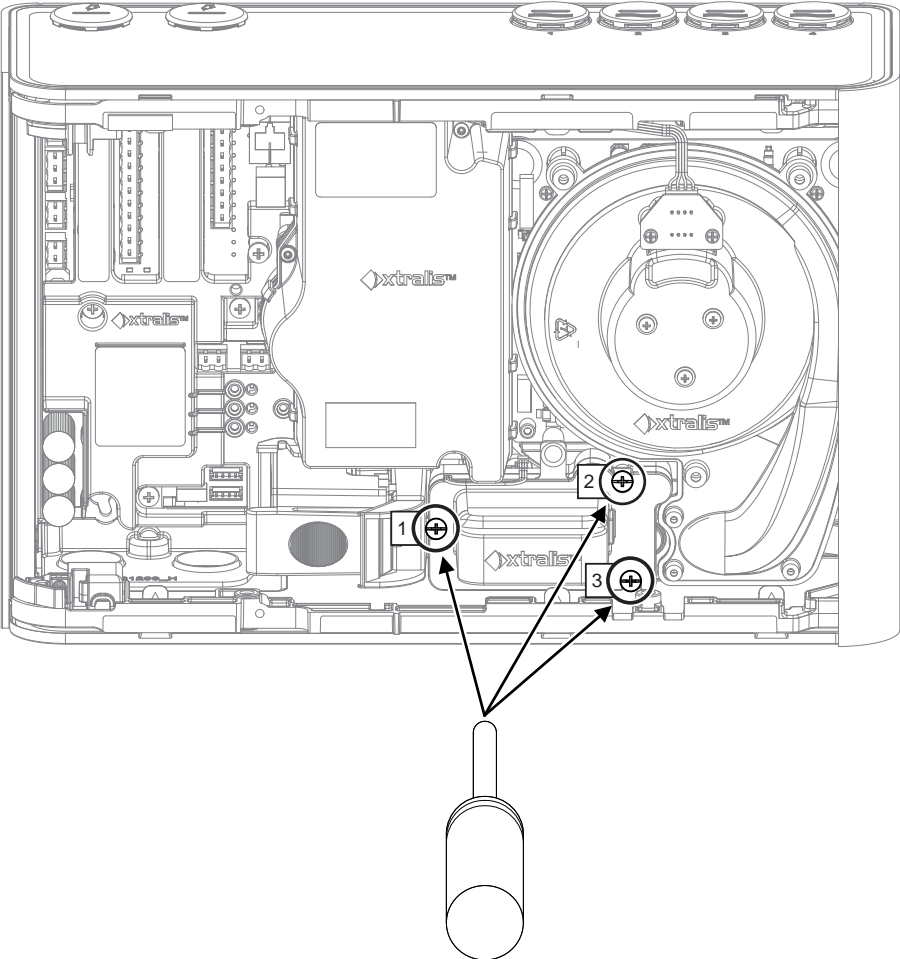

Figure 7-21: Undo Sampling Module screws

6. Remove the Sampling Module. Be sure to include the rubber seal on the base of the Sampling Module (Figure 7-22).

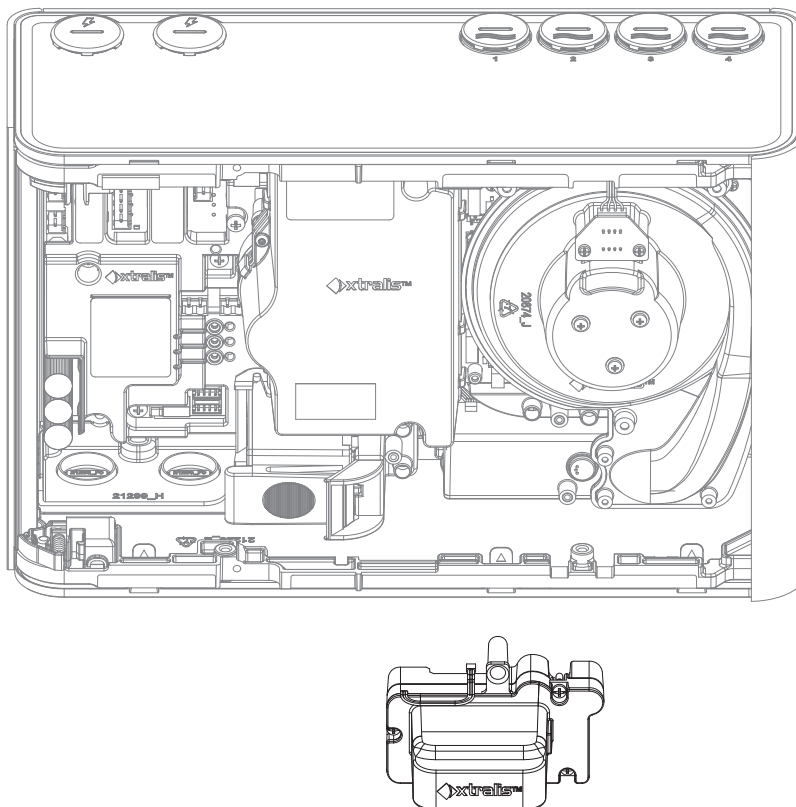

Figure 7-22: Remove Sampling Module

Installing a replacement Sampling Module

1. Firmly press the Sampling Module into the detector in the direction of the arrow shown so that the rubber seal on the Sampling Module is seated on the pipes in the detector (Figure 7-23). You will feel the module slide onto the pipes.

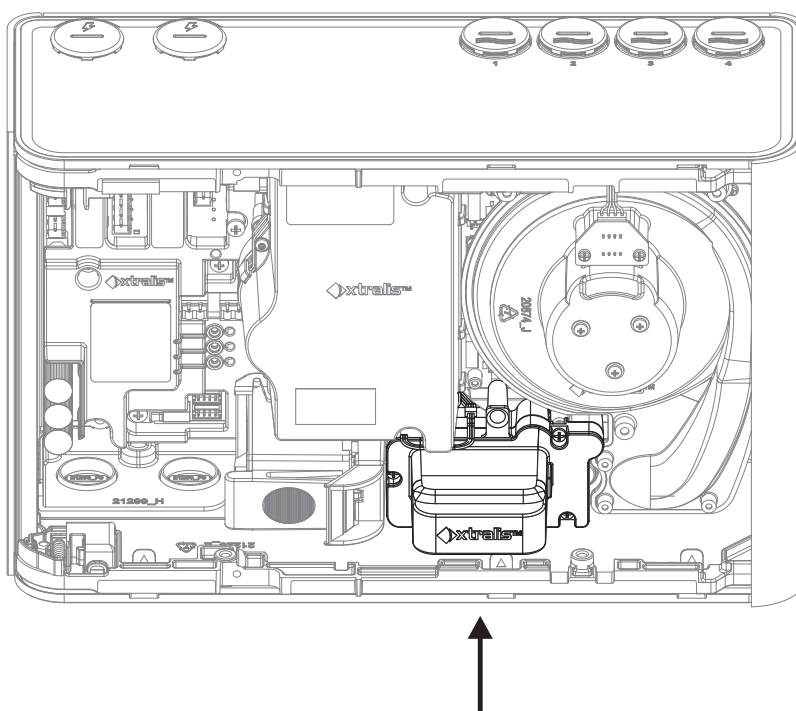

Figure 7-23: Reinstall Sampling Module

2. Tighten the three screws and re-connect the Sampling Module cable (Figure 7-19).

7.8 Spare Parts

The detector's internal components are field replaceable. Table 7-2 below provides a complete list of these spare parts and each one's ordering number.

Table 7-2: Spare Parts

Part No.	Description
VSP-960	VESDA-E VEP Mounting Bracket
VSP-962	VESDA-E VEP Filter
VSP-963	VESDA-E VEP Aspirator
VSP-964	VESDA-E VEP Chamber Assembly
VSP-965	VESDA-E VEP Sampling Module

8 Troubleshooting

If the VEP-A10-P detector identifies a fault condition, the Fault LED on the front of the detector illuminates and an event containing details of the condition is written to the Xtralis VSC active event list and the detector's event log.

The Xtralis VSC software can be used to obtain specific information on the event to enable further investigation and correction of the fault. The Xtralis VSC Online Help contains descriptions of each fault and recommended corrective actions.









8.1 Fault Reporting through Relays

VESDA-E devices are often interfaced with Fire Alarm Control Panels (FACPs) or building management systems (BMS) via relays. In such instances the fault relays signal a fault condition to the FACP or the BMS. Use the Xtralis VSC software to further investigate the fault.

8.2 Troubleshooting with the Front Panel Display

The main screen of the VESDA-E VEP-A10-P touchscreen display features a range of fault indicators. When a fault is generated, the respective indicator will illuminate. Use Xtralis VSC to further investigate the fault by reviewing the event log.

Table 8-1: Fault Indicators

Fault Indicator	Description
	General detector fault, for example an electronics hardware fault, or fault test procedure in progress. Refer to Section 5.4 on page 57 for further information on the fault test procedure.
	Airflow fault, for example Airflow not within the expected range.
	Power fault, for example Mains Power failure.
	Communications fault, for example disconnected wiring on VESDAnet.
	Aspirator fault, for example the aspirator impeller cannot rotate due to contamination or the aspirator has an electrical fault.
	Filter fault, for example the filter is not inserted, or requires replacement.
	Smoke detection fault, for example a Smoke Sensor or Sampling Module hardware failure. This indicator will also be lit when the Autolearn Smoke function is canceled due to an alarm occurring during the Autolearn process.
	Expansion Module fault, for example a Remote Display which has previously been in the same VESDA Zone as the detector is now not found on the VESDAnet.

8.3 Troubleshooting with Xtralis VSC

The details of fault conditions are written to the detector's event log. The event log can be retrieved using Xtralis VSC and the date, time, fault number and description of any faults can be viewed.

The Xtralis VSC software also displays any current faults in the active event list. The list displays the date and time of the fault, the serial number of the device on which the fault has occurred, the zone number, fault number, and a description of the fault.

For detailed information about a fault, select the fault in the active event list or the event log then press F1. Xtralis VSC will display the cause and troubleshooting information for the selected fault. Alternatively, select **Help->VSC Help**, then select **Troubleshooting > Fault Codes**.

- For fault codes above 750, select VESDA-E.
- For fault codes between 0 and 89, select VESDAnet faults.

The fault is removed from the active event list once it is cleared.

A Commissioning Forms

This is the main commissioning form for each customer site.

Table A-1: VESDA-E commissioning form

Customer Name	
Site Address	
Installer (Name & Contact)	
Commissioner (Name & Contact)	

Commissioning Checks	Done (Y/N)	Notes
Aspirator speed setting and pipes in use configured as per ASPIRE.		
Detector alarm thresholds configured.		
Detector Normalised.		
GPI connected and tested (if used).		
Reset detector – Check that detector is running with no faults.		
The alarm and fault relay outputs are wired to the fire panel.		
Test the detector's Relay outputs connection to the fire panel using the Xtralis VSC Relay Test command. (Turn each relay on/off individually.) See below.		
Relay 1 Tested (Default assignment = Disable)		
Relay 2 Tested (Default assignment = Minor Fault)		
Relay 3 Tested (Default assignment = Urgent Fault)		
Relay 4 Tested (Default assignment = Alert)		
Relay 5 Tested (Default assignment = Action)		
Relay 6 Tested (Default assignment = Fire 1)		
Relay 7 Tested (Default assignment = Fire 2)		
Fire 1 relay connection from Detector to fire panel tested (using the Xtralis VSC Alarm Test command).		
Urgent Fault relay connection to fire panel tested (using the Xtralis VSC Urgent Fault Test command).		
Minor Fault relay connection to fire panel tested (using the Xtralis VSC Minor Fault Test command).		
Smoke Test done. Transport time tested.		

Commissioning checklist for the Remote Display/Relay – If used.

Commissioning Checks	Done (Y/N)	Notes
Zone number configured.		
Have checked that no faults are reported.		
The alarm and fault relay outputs are wired to the fire panel.		
Test the Remote Display/Relay's Relay output connections to the fire panel using the Xtralis VSC Relay Test command. (Turn each relay on/off individually.) See below.		
Relay 1 Tested (Default assignment = Disable)		
Relay 2 Tested (Default assignment = Minor Fault)		
Relay 3 Tested (Default assignment = Urgent Fault)		
Relay 4 Tested (Default assignment = Alert)		
Relay 5 Tested (Default assignment = Action)		
Relay 6 Tested (Default assignment = Fire 1)		
Relay 7 Tested (Default assignment = Fire 2)		
Fire 1 relay connection from Remote Display/Relay to fire panel tested (using the Xtralis VSC Alarm Test Command for the detector).		
Urgent Fault relay connection from Remote Display/Relay to fire panel tested (using the Xtralis VSC Alarm Test Command for the detector).		

Client Representative Name	
Test witnessed by:	Date:

Hand Over Documents	
Copy of this form ASPIRE Installation Data Pack ASPIRE Bill of Materials Configuration printout from Xtralis VSC for each detector Configuration printout from Xtralis VSC for each display module Smoke test results Forms required for compliance with local codes and standards	

Customer's Signature	Date:
Commissioner's Signature	Date:

A.1 VEP-A10-P Detector Commissioning Configuration

To record the detector's configuration you can print it using Xtralis VSC. To print the configuration select the detector on the Xtralis VSC tree view at left and choose the Print command on the File menu.

A.2 ASPIRE Data

Print the ASPIRE Installation Data Pack (IDP) in order to record the ASPIRE modeling results for the system.

A.3 Smoke Test

Table A-2: Smoke Test commissioning form

Test Results	
Test Method	
Type of Smoke	
Test Date	

A.4 Air Sampling Test Results

Table A-3: Air Sampling Test results commissioning form

		Pipe 1	Pipe 2	Pipe 3	Pipe 4
	Transport Time from End Cap Hole				
Test 1	Initial Response				
	Fire1 (Alarm)				
	Peak Smoke				
Test 2	Initial Response				
	Fire1 (Alarm)				
	Peak Smoke				

This page is intentionally left blank.

B Glossary

Table B-1: Glossary

	Term	Description
A	Aspirator	Impeller type fan used to draw sampled air into the detector.
	AutoLearn Smoke	A feature which allows the detector to learn its environment (background pollution, differences between day and night operations within the facility etc) in order to set appropriate alarm thresholds for that environment.
	AutoLearn Flow	A feature which allows the detector to learn its airflow behavior in the installed environment. This information is used by the detector to set appropriate airflow trouble thresholds.
C	Capillary Tubes	Flexible tubes attached to the sampling pipe network for sampling specific areas away from the sampling pipe.
	Commissioning	The process of making a smoke detection system operational.
	Condition	For example, Fire 1 condition, Urgent Fault condition. The detector is said to be in the Fire 1 condition when it has detected a Fire 1 alarm.
D	Disable	When the detector is disabled the detector will not signal alarms and faults via its relays. The detector signals that it is disabled using Relay 1. (Disable was previously referred to as isolate.)
E	Event Log	A data log of events (for example, alarms, troubles, user commands) which is stored in the detector.
F	Fault	An urgent fault is a condition where the system requires urgent attention as it may be unable to detect an alarm condition. A minor fault is a condition where the system requires attention or maintenance, but is still able to detect an alarm condition.
	Fire Alarm Control Panel (FACP)	A central monitoring and control system to which all smoke detectors report their status.
G	General Purpose Input (GPI) Unmonitored	An input to the detector which can be used to initiate a user configurable action. Applying a voltage between 5V and 30VDC triggers the selected action.
	General Purpose Input (GPI) Monitored	The monitored GPI senses contact closure and is configurable to initiate the same actions as the unmonitored GPI. In particular, it can be used to monitor the power supply.
H	High Airflow Environment	Where there are 10 or more air exchanges per hour.
	High Level Interface (HLI)	A communications interface between a VESDA device and other pieces of equipment using another communications protocol.
L	Latching	If the cause of a condition is removed (for example, smoke decreases below the threshold) and latching is enabled, the detector “remembers” the condition and holds the corresponding relays and displays in the active state as though the cause of the condition were still active.

Table B-1: Glossary (continued...)

	Term	Description
O	Obscuration	The reduction in light transmission per meter or per foot due to the presence of particulates.
R	Referencing	Referencing is a technique used to reduce false alarms. It requires VESDAnet. A separate detector takes readings of the background level of smoke and pollutants outside of the protected area. These readings are then referenced to the readings from the detectors in the protected area. This allows the internal detectors to determine if a rise in smoke levels is due to background pollution or a problem inside the protected area.
	Relay	A device on a detector that has an electrical contact which can be configured to close when a condition occurs such as fire alarm or a fault in the detector. This is the primary method used to signal alarms and faults.
S	Sampling Network	The pipe network constructed to allow the VESDA-E detector to draw air for sampling.
	Sensitivity	Sensitivity refers to sensitivity to smoke. A high sensitivity denotes response to a lower concentration of smoke than a low sensitivity.
	Standby	When the detector is in standby mode the aspirator is turned off and the detector will not signal alarms via its relays. The detector signals that it is in Standby mode using Relay 1.
Z	Zone	A defined area within the protected premises from which an alarm signal can be received.

Index

- A**
- access level
 - ADM 56, 73
 - DST 56, 73
 - USR 56
 - accessories
 - display module 9, 39, 41
 - programmer 41, 97
 - action 5-6, 12, 36, 39, 42, 73
 - airflow 65, 97
 - alert 5-6, 12, 36, 39, 73
 - area coverage 3
 - aspirator ... 3, 5-6, 8, 11, 17, 44-45, 47, 57, 59, 65, 69, 77, 79, 86, 96-97, 103
 - autolearn 12
- B**
- battery 19, 44, 79
 - button
 - disable 5-6, 41, 57, 68
 - lockout 68, 70
 - reset 6, 45, 57
- C**
- cable entry point 3, 11, 19-20, 35, 37
 - capillary tubes 103
 - chamber assembly 3, 5, 88, 96
 - checklist
 - air sampling results 101
 - commissioning 99
 - installation 46
 - smoke test 101
 - commands
 - cancel AutoLearn flow 58
 - cancel AutoLearn smoke 58
 - disable 57
 - enable 57
 - normalize air flow 57
 - rebuild zone list 58
 - reset 57
 - return to factory defaults 59
 - set system date and time 59
 - standby 57
 - start air flow fault test 59
 - start alarm test 59
 - start AutoLearn flow 58
 - start AutoLearn smoke 58
 - start lamp test 59
 - start major fault test 58
 - start minor fault test 59
 - start relay test 59
 - commissioning 77, 99, 103
 - smoke test 78
 - connection 9, 49
 - add 50
 - ethernet 51, 53
 - USB 50
 - VESDAnet 55
 - WiFi 51, 54
- D**
- detector
 - invert 21
 - open the door 80
 - remove fascia 84
 - replace aspirator 86
 - replace chamber assembly 88
 - replace sample module 92
 - replacing the filter 81
 - set to standby 79
 - dimensions 11, 13
 - disable 5-6, 39, 41, 57, 68-70, 79, 103
 - display module 9, 39, 41
- E**
- EOL resistor 19, 41-43
 - ESD 35, 80, 84, 88
 - ethernet 3, 5, 9, 11, 19, 36-37, 51, 56, 61, 68, 73

event log3, 12, 56, 64-65, 73, 97, 103
 exhaust 5, 11, 17-20, 31, 45-47

F

FACP39, 42, 97, 103
 fault 3, 5-7, 9, 12, 36, 39, 42, 45, 58, 65, 68,
 71, 73, 77, 81, 97-98
 airflow 97
 filter81, 97
 network 97
 power 97
 system 97
 urgent 97
 zone 97
 features 3
 filter3, 5, 12, 21, 56, 73, 79, 81, 96-97
 fire 1 5-6, 12, 36, 39, 42, 73
 fire 25-6, 12, 36, 39, 73
 front panel6, 41, 97

G

GPI ... 3, 6-7, 19, 36, 39, 41-44, 49, 68, 97, 103
 external reset 68
 inverted reset 68
 isolate 68
 mains OK 68
 monitored3, 19, 36, 41, 43-44, 68, 103
 power supply voltage41, 68
 reset + isolate 68
 standby mode 68
 unmonitored 3, 36, 41-42, 68, 103
 use night-time threshold 70

H

HLI 9, 55, 103

I

isolate36, 39, 70

L

LED 3, 5-6, 45, 68, 79, 97

M

maintenance 12
 check pipe flow 79
 check pipe network 79
 clean sampling point 79
 filter inspection 79
 flush pipe network 79
 pipe integrity smoke test 79
 power supply 79
 mounting 11, 29, 31, 46
 bracket 19
 location 20
 locking mechanism 29
 orientation 20
 screws 19
 mounting template 31

N

normalize airflow 47, 57, 65, 77-78

O

obscuration64, 103
 options 64
 airflow 65
 ethernet 61
 smoke threshold 64
 WiFi 63

P

PIN code 56
 pipe
 airflow 65
 diameter 17
 endcap 17, 77
 exhaust 18
 flow rate 17, 77
 inlet pipes 17
 inlet ports17, 19
 installation 17
 length 11
 maintenance 79

mounting	20, 29, 31
network	11, 17, 103
network design	17-18
network testing	78
size	11
pipe flow rate	17, 77
pipe length	3
pipe network	3, 5, 17, 65
pipes in use	7, 17, 65
polarity	36-37, 45
port	
ethernet	36-37, 55
Ethernet	9
USB	9, 36-37
WiFi	9
power	6
battery	44
cabling	35-36, 46
consumption	11
GPI supply voltage	41
socket	36
supply	36, 43
voltage range	36
wiring	36
power source	36
power supply	19, 36
monitoring	41
power up	45, 47

R

referencing	9, 12
relays	3, 5-6, 9, 11, 36, 39, 42, 45, 57, 68, 71, 97, 103
action	36
alert	36
fault	36, 39
fire	36, 39
isolate	36
options	71
remote display	9, 60, 97
reset	5-6, 41, 45, 57, 68, 70, 77

S

sampling module	5, 92, 96
sensitivity	3, 11, 103
settings	73
default	73
significant smoke change	64
specifications	11
alarm range	11
dimensions	11
power	11
weight	11
standby	57, 69, 79, 81, 86, 88
supply voltage	11, 36

T

temperature	11, 44
thresholds	5, 11
action	6, 11-12, 73, 77
alert	6, 11-12, 73, 77
fire 1	6, 11-12, 39, 73, 77
fire 2	6, 11-12, 73, 77
touch screen	7
troubleshooting	97-98

U

USB	5, 9, 11, 50
interface lead	19

V

VESDAnet	5, 9, 37, 41, 46, 55, 60, 68, 70, 73, 101, 103
polarity	37

W

weight	11
WiFi	5, 9, 11, 56, 63, 68, 73
wiring	35, 41-42
address loop module	42
FACP	42
power	36
VESDAnet	37

Z

zone 58, 60, 79, 103